



Your Wellness Solution Provider



Impulse (Qingdao) Health Tech Co., Ltd.
Add: No. 369 Huashan 2nd road, Jimo, Qingdao, China
Tel: 0086 532 85793158 or 0086 532 83958616
Fax: 0086 532 83958619
<http://www.impulsefitness.com>
E-mail: sales@impulsefitness.com





Your Wellness Solution Provider



Your Wellness Solution Provider



INTRODUCTION

In 1970s, industrial development in Taiwan was thriving. The founder of Impulse, Mr. Roger Chu took aim of exporting fitness equipment to Western countries. In 1991, Impulse moved production from Taiwan to Qingdao, and became the very first fitness manufacturer in Mainland China. With nearly 30 years' experience, Impulse (Qingdao) Health Tech Co., Ltd. was founded in 2004. In 2011, Impulse brought in Venture Capital and aiming at stock market. In September 2017, Impulse (Qingdao) Health Tech Co., Ltd. did IPO successfully in Shenzhen stock market and achieved breakthrough in capital market.

Impulse has abundant and solid R&D team and advanced to international level. Impulse cooperated with plenty of research institutions, such as China Institute of Sports Science, Beijing University, Beijing Forestry University and also some foreign organizations. Impulse has achieved wealthy honors, including Key Hi-tech Enterprise of China Torch Program, National Enterprise Technology Center, Shandong Province Industrial Design Center, Core Member of China New Fitness Equipment Technology Innovation Association, etc. Impulse is also one of the drafters of National Standard of Fitness Equipment. With the sales network and customer resources all across the world, Impulse R&D team can accurately gather first-hand information regarding market trend and sales figure. By analyzing the information as the foundation of R&D, Impulse prepares product development in advance so it can response much faster to customer needs.

Impulse industrial park is located in Jimo which is in the north of Qingdao. Qingdao has a world top-ten harbor which has convenient transportation and daily ocean freights to worldwide ports. The industrial park is composed by Toyota Production System that can manufacture many different product lines very fast at the same time. It has many advanced machinery and quality control equipments, such as plasma cutting machine, CNC 3D tube bending machine, welding robot, automatic electrostatic powder coating line, three-coordinate measuring machine, energy dispersive X-ray fluorescence spectrometer and so on. These can all ensure the high quality standard of Impulse product.

Impulse understands customer needs well and created full range of indoor and outdoor fitness product system. Impulse sales network is across numerous countries and areas, it's providing professional fitness equipments and sports facilities to gyms, star hotels, corporations, families and individuals. Impulse cardio equipment combines innovative technology that integrated exercise, entertainment, intelligence and sharing. With many patents applied, the equipment has better longevity, easier maintenance and lower operation cost. Impulse strength equipment has strong lineup which has ergonomic design, humanity details and comfortable user experience. There has been a great deal of effort devoted to it. All steel structures and important parts are selected carefully, and the motion curve is adjusted precisely. Impulse outdoor fitness equipment and sport facility can meet various needs of different ages, as well as creating beautiful scenery for community.

Impulse devotes itself to be a reliable fitness expert trusted by global consumers and lead the way to wellness. Impulse will be your wellness solution provider.



CARDIO

R Series



Impulse Touch Screen Operation System

1920x1080 resolution brings high definition TV contents meeting SMPTE (Society of Motion Picture and Television Engineers) standard.

A Quad-core 1.8Ghz processor with 2G memory provides powerful computing capability par with personal computer to make sure you gain unparalleled experience whenever interactive with treadmill, enjoy video or suffering internet.

Trainers could connect to internet by turning this treadmill into a terminal of information world. This machine would accompany with you to advancing with the era.

For club owners, cable TV (ATSC or DVB-T2/T or DVB-C or ISDB supported) and Virtual Scenery integrated in the OS would create better entertainment environment for trainers.

More fun, more renewals, more possibility to make decisions.



Well designed quick start page combine the key parameters and interfaces to the next level, as well as the most important quick-start button. Whatever users want to know necessary information, make advanced settings, or exercise directly, this page is enough.



Exercise Program and key parameters at a glance. The button layout is extremely convenient, what you see is what you get.

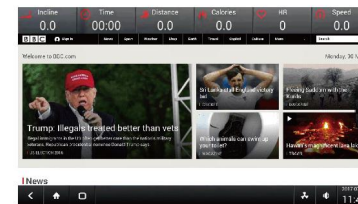

We recognize the importance of maintaining online for you, through the system comes with a browser, you will not miss any news in workout.



Providing various entertainment experiences, including video and music play. Virtual Scene provides various sites all over the world for trainers to enjoy while exercising.



RT950
TREADMILL



RT750
TREADMILL

Model	RT950	RT750
Certification	CE,ETL,EN957	CE,ETL,EN957
Max User Weight	180kg/396lbs	180kg/396lbs
AC/DC	AC	AC
Power Requirement	15A	15A
Electrical Receptacle & Plug	220-240V	220-240V
Motor Power	5HP	5HP
Motor Peak Power	7.5HP	7.5HP
Speed range	1-25km/h (0.6-15mph)	1-25km/h (0.6-15mph)
Incline range	0-15%	0-15%
One Touch Buttons	3%,6%,9%,12%(Incline);3,6,9,12(Speed)	3%,6%,9%,12%(Incline);3,6,9,12(Speed)
Handle bar Control	Yes	Yes
Console Display	18.5" TFT	7 LED + Matrix 16x32
Console Readouts	Heart rate,%Heart rate,Time in zone,Average Speed,Pace,Time Elapsed,%Time Remaining, Calories,Calories/Hour,Distance,Speed,Incline, 1/4 mile or 400 meters motivational track	Heart rate, %Heart rate, Time in zone, Average Speed, Pace, Time Elapsed, %Time Remaining, Calories, Calories/Hour, Distance, Steps,Speed, Incline
Metric/English	Metric/English	Metric/English
Touch Screen	Yes	No
Entertainment (TV, WiFi etc.)	Music/TV(cable)/WiFi/Internet/Virtual Scenery	No
Programs	Cardio,Random,Fatburn,Hills,Interval, HR,5km,Fireman test	Manual , Cardio,Interval,Burn Calories, Heart Rate,Advanced,
HR Monitor	Contact&Telemetry	Contact&Telemetry
Roller Diameter	Front:88.9mm (3.5") Back:76mm (3")	Front:88.9mm (3.5") Back:76mm (3")
Deck	Reversible 1"Deck	Reversible 1"Deck
Running surface	558 x 1524(mm)/22" x 60"	558 x 1524(mm)/22" x 60"
Belt Thickness	1.6mm	1.6mm
Belt Brand	Habasit	Habasit
Step-up Height	245mm	245mm
Suspension System	Pulflex™ Commercial Suspension System	Pulflex™ Commercial Suspension System
Accessory Storage	IPAD/Phone Holder/Magazine Holder/2 Bottle Holders	IPAD/Phone Holder/Magazine Holder/2 Bottle Holders
USB Charger	Yes	Yes
USB Data Exchange	Yes	No
Fan	Yes (3 speed level)	Yes (3 speed level)
Multi-language Display	Yes	Yes
Gross Weight	266.8kg/587lbs	273.7kg/602.1lbs
Net Weight	203kg/446.6lbs	207.2kg/455.8lbs
Product Dimension	2080 x 950 x 1590(mm)/81.9" x 37.4" x 62.6"	2080 x 950 x 1590(mm)/81.9" x 37.4" x 62.6"
Packing size	2 Packages: Box 1:2230 x 970 x 480(mm) 87.8" x 38.2" x 18.9" Box 2:1145 x 1105 x 390(mm) 45" x 43.5" x 15.4"	2 Packages: Box 1:2230 x 970 x 480(mm) 87.8" x 38.2" x 18.9" Box 2:1145 x 1105 x 390(mm) 45" x 43.5" x 15.4"
40GP	40Sets	40Sets



RT930
TREADMILL



RT700
TREADMILL



RT500
TREADMILL

Model	RT930	RT700	RT500
Certification	CE,ETL,EN957	CE,ETL,EN957	CE,ETL,EN957
Max User Weight	150kg/330lbs	180kg/396lbs	150kg/330lbs
AC/DC	AC	AC	AC
Power Requirement	15A	15A	15A
Electrical Receptacle & Plug	220-240V	220-240V	220-240V
Motor Power	3HP	4HP	3HP
Motor Peak Power	4.5HP	6HP	4.5HP
Speed range	1-20km/h (0.6-12mph)	1-25km/h (0.6-15mph)	1-20km/h (0.6-12mph)
Incline range	0-15%	0-15%	0-15%
One Touch Buttons	3%,6%,9%,12%(Incline); 3,6,9,12(Speed)	2%,5%,8%,(Incline);3,6,9(Speed)	No
Handle bar Control	No	Yes	No
Console Display	11.6" TFT	7 LED + Matrix 16x40	7 LED + Matrix 16x40
Console Readouts	Heart rate, Time Elapsed, Calories, Distance, Speed, Incline, 1/4 mile or 400 meters motivational track		
Metric/English	Metric/English	Metric/English	Metric/English
Touch Screen	Yes	No	No
Entertainment (TV, WiFi etc.)	Music/TV(cable)/WiFi/Internet Virtual Scenery	No	No
Programs	Cardio,Random,Fatburn,Hills, Interval,HR,5km,Fireman test	Manual , Cardio,Interval,Burn Calories,Heart Rate,Advanced, Contact&Telemetry	Manual ,Cardio,Interval,Burn Calories,Heart Rate,Advanced, Contact&Telemetry
HR Monitor	Contact&Telemetry	Contact&Telemetry	Contact&Telemetry
Roller Diameter	Front:88.9mm(3.5")Back:76mm(3")	Front:88.9mm(3.5")Back:76mm(3")	Front:88.9mm(3.5")Back:76mm(3")
Deck	Reversible 1"Deck	Reversible 1"Deck	Reversible 1"Deck
Running surface	558x1524(mm)/22" x 60"	558x1524(mm)/22" x 60"	558x1524(mm)/22" x 60"
Belt Thickness	2.5mm	3.3mm	2.5mm
Belt Brand	Siegling	Siegling	Siegling
Step-up Height	245mm	245mm	245mm
Suspension System	Pulflex™ Commercial Suspension System		
Accessory Storage	Phone Holder/ 2 Bottle Holders	IPAD/Phone Holder/Magazine Holder/ 2 Bottle Holders	IPAD/Phone Holder/Magazine Holder/2 Bottle Holders
USB Charger	Yes	No	No
USB Data Exchange	Yes	No	No
Fan	Yes (3 speed level)	Yes (3 speed level)	Yes (3 speed level)
Multi-language Display	Yes	No	No
Gross Weight	268.6kg/590.9lbs	273kg/600.6lbs	272.5kg/599.5lbs
Net Weight	205.8kg/452.8lbs	206.6kg/454.5lbs	206.1kg/453.4lbs
Product Dimension	2080x876x1513(mm) 81.9"x34.5"x59.6"	2080x876x1513(mm) 81.9"x34.5"x59.6"	2080x876x1513(mm) 81.9"x34.5"x59.6"
Packing size	2 Packages: Box 1:2230x970x480(mm) 87.8"x38.2"x18.9" Box 2:975x965x280(mm) 38.4"x38.0"x11.0"	2 Packages: Box 1:2230x970x480(mm) 87.8"x38.2"x18.9" Box 2:975x965x280(mm) 38.4"x38.0"x11.0"	2 Packages: Box 1:2230x970x480(mm) 87.8"x38.2"x18.9" Box 2:1145x1105x390(mm) 45"x43.5"x15.4"
40HQ	51Sets	51Sets	51Sets
40GP	42Sets	42Sets	42Sets



Model	RU930
Certification	ETL/CE/EN957
Max User Weight	160kg/350lbs
Brake Type	Self powered hybrid brake
Resistance Brake Power	350w
Resistance Levels	20
Crank	Standard
Pedal	Single sided weighted pedal
Flywheel Weight	8kg
One Touch Buttons	No
Handle bar Control	3 riding positions , with contact heart rate grips
Console Display	11.6" TFT
Console Readouts	Distance, time, speed, watt, calories, RPM, heart rate
Metric/English	Metric&English
Touch Screen	Yes
Entertainment (TV, Wifi etc.)	Music/TV (cable) /WIFI/Internet/Virtual Scenery
Programs	11
HR Monitor	Contact&telemetry
Accessory Storage	Yes
USB Charger	Yes
USB Data Exchange	Yes
Multi-language Display	Yes
Special Features	11.6" touch screen for bikes and cross-trainers Internet (wireless or wired), video streaming apps,
Gross Weight	87.3kg/192.1lbs
Net Weight	67kg/147.4lbs
Product Dimension	1090x660x1492/43"x26"x59"
Packing size	1160x405x1020(mm)/46"x16"x40.2"
40HQ	116Sets



RU930
UPRIGHT BIKE



RU700
UPRIGHT BIKE



RU500
UPRIGHT BIKE

Model	RU700	RU500
Certification	ETL/CE/EN957	ETL/CE/EN957
Max User Weight	180kg/396lbs	160kg/352lbs
Brake Type	Self Powered Hybrid Brake	Self Powered Hybrid Brake
Resistance Brake Power	450W	350W
Resistance Levels	25	20
Crank	Oversized	Standard
Pedal	Oversize dual-sided pedals with integrated straps	Single sided weighted pedal
Flywheel Weight	9kg	8kg
One Touch Buttons	No	No
Handle bar Control	3 riding positions , with contact heart rate grips and on-your-finger-tips control	3 riding positions , with contact heart rate grips
Console Display	7window +dot matrix	7window +dot matrix
Console Readouts	Distance, time, speed, watt, calories, heart rate	Distance, time, speed, watt, calories, RPM, heart rate
Metric/English	Metric&English	Metric&English
Touch Screen	No	No
Entertainment (TV, Wifi etc.)	No	No
Programs	11	11
HR Monitor	Contact&Telemetry(polar)	Contact&Telemetry
Accessory Storage	Yes	Yes
USB Charger	No	No
USB Data Exchange	No	No
Multi-language Display	No	No
Special Features	On-your-finger-tips, Ergonomically designed handle bars, Two-sided pedals, K-O-P-S biomechanics, Easy to service	On-your-finger-tips, Ergonomically designed handle bars, Two-sided pedals, K-O-P-S biomechanics, Easy to service
Gross Weight	84.8kg/186.6lbs	81kg/178.2lbs
Net Weight	67kg/147.4lbs	68kg/149.6lbs
Product Dimension	1093x660x1492(mm)/43"x26"x59"	1093x660x1492mm/43"x26"x59"
Packing Size	1160x405x870(mm)/46"x16"x34"	1160x405x870mm/46"x16"x34"
40HQ	172Sets	172Sets

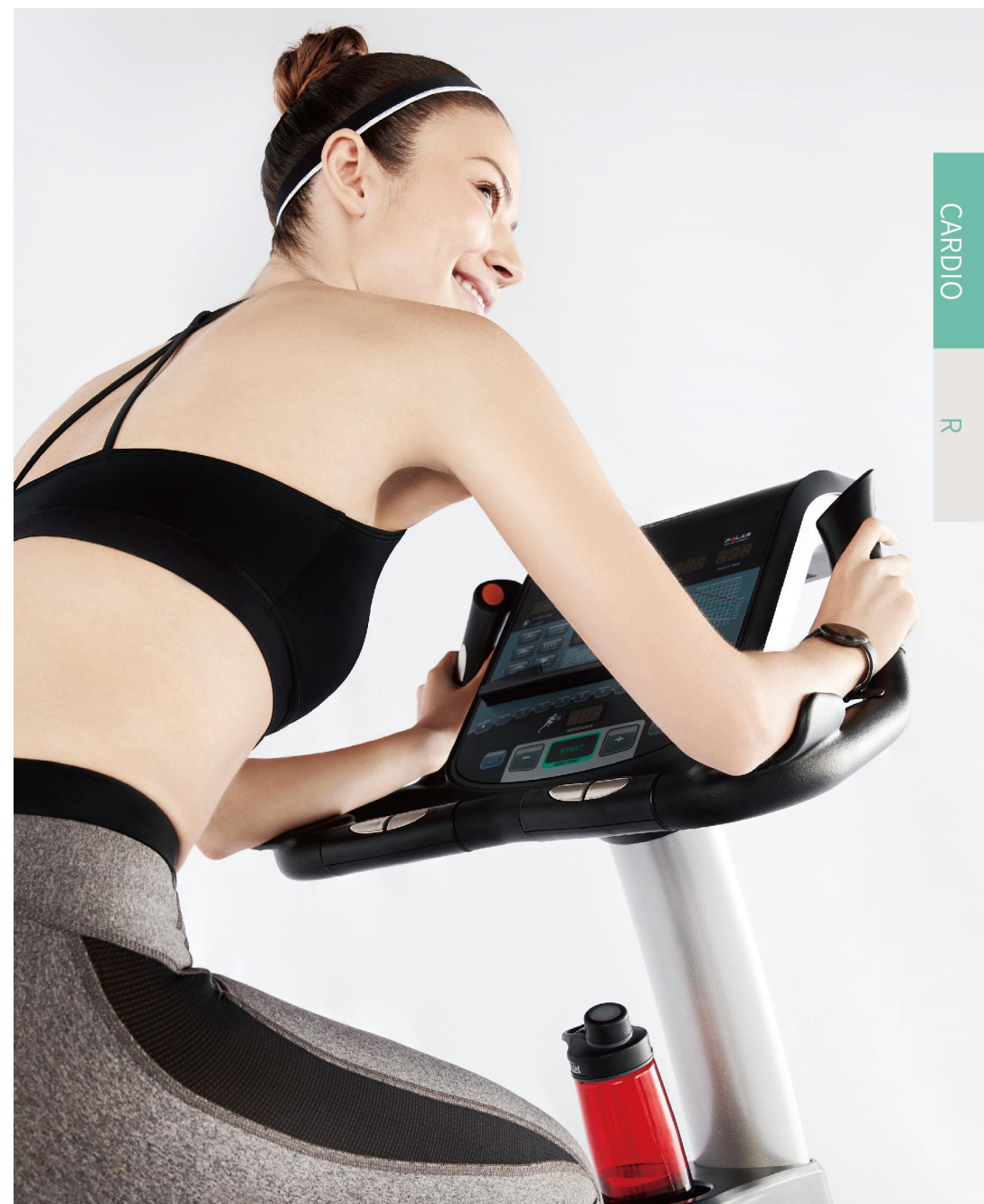



RR930 RECUMBENT BIKE

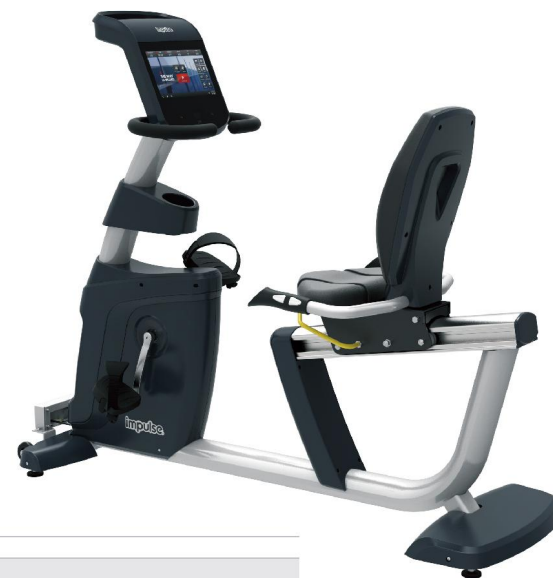

Model	RR930
Certification	ETL/CE/EN957
Max User Weight	160kg/352lbs
Brake Type	Self Powered Hybrid Brake
Resistance Brake Power	350W
Resistance Levels	20
Crank	Standard
Pedal	Single sided weighted pedal
Flywheel Weight	8kg
One Touch Buttons	No
Handle bar Control	ErgoNomically designed seat-side handles with contact heart rate grips on-your-finger-tips control
Console Display	11.6" TFT
Console Readouts	Distance, time, speed, watt, calories, RPM, heart rate
Metric/English	Metric&English
Touch Screen	Yes
Entertainment (TV, Wifi etc.) Programs	Music/TV (cable) /WIFI/Internet/Virtual Scenery 11
HR Monitor	Contact&Telemetry
Accessory Storage	Yes
USB Charger	Yes
USB Data Exchange	Yes
Multi-language Display	Yes
Special Features	11.6" touch screen for bikes and cross-trainers Internet (wireless or wired), video streaming apps
Gross Weight	105.4kg/231.9lbs
Net Weight	87kg/191.4lbs
Product Dimension	1650x650x1400(mm)/65"x26"x55"
Packing Size	1615x435x890(mm)/63.6"x17"x35"
40GP	72Sets



Model	RR700	RR500
Certification	ETL/CE/EN957	ETL/CE/EN957
Max User Weight	180kg/396lbs	160kg/352lbs
Brake Type	Self Powered Hybrid Brake	Self Powered Hybrid Brake
Resistance Brake Power	450W	350W
Resistance Levels	25	20
Crank	Oversized	Standard
Pedal	Oversize dual-sided pedals with integrated straps	Single sided weighted pedal
Flywheel Weight	9kg	9kg
One Touch Buttons	No	No
Handle bar Control	ErgoNomically designed seat-side handles with contact heart rate grips on-your-finger-tips control	ErgoNomically designed seat-side handles with contact heart rate grips on-your-finger-tips control
Console Display	7window +dot matrix	7window +dot matrix
Console Readouts	Distance, time, speed, watt, calories, heart rate	Distance, time, speed, watt, calories, RPM, heart rate
Metric/English	Metric&English	Metric&English
Touch Screen	No	No
Entertainment (TV, Wifi etc.)	No	No
Programs	11	11
HR Monitor	Contact&Telemetry(polar)	Contact&Telemetry
Accessory Storage	Yes	Yes
USB Charger	No	No
USB Data Exchange	No	No
Multi-language Display	No	No
Special Features	On-your-finger-tips, Ergonomically designed handle bars, Two-sided pedals, K-O-P-S biomechanics, Easy to service, walk-through design	On-your-finger-tips, Ergonomically designed handle bars, Two-sided pedals, K-O-P-S biomechanics, Easy to service, walk-through design
Gross Weight	104.6kg/230.1lbs	100.7kg/222lbs
Net Weight	83kg/182.6lbs	79kg/173.8lbs
Product Dimension	1650x650x1400(mm)/65"x26"x55"	1650x650x1400(mm)/65"x26"x55"
Packing Size	1615x370x850(mm)/63.6"x14.5"x33.5"	1615x370x850(mm)/63.6"x14.5"x33.5"
40HQ	129Sets	129Sets





Model	RE930
Certification	CE
Max User Weight	160kg/352lbs
Power Supply	60W
Brake Type	Self Powered Hybrid Brake
Resistance Brake Power	350W
Resistance Levels	20
Electrical Receptacle & Plug	Yes
Incline range	No
Stride Length	533mm/21"
Pedal	Pedal with cushioned gel pads
Pedal Spacing	1"
Step-up Height	190mm/7.5"
One Touch Buttons	No
Handle bar Control	Yes
Console Display	11.6" TFT
Console Readouts	Speed,Time,Calorie,RPM,Distance,Heart rate,Resistance,etc.
Metric/English	Metric&English
Touch Screen	Yes
Entertainment (TV, Wifi etc.)	Music/TV (cable) /WIFI/Internet/Virtual Scenery
Programs	11
HR Monitor	Contact&Telemetry
Accessory Storage	Cup holder, Magazine Holder, Phone Holder
USB Charger	Yes
USB Data Exchange	Yes
Multi-language Display	Yes
Special Features	On-your-finger-tips, Ergonomically designed handle bars, Easy to service
Gross Weight	174.9kg/384.8lbs
Net Weight	118kg/259.6lbs
Product Dimension	2179x742x1610(mm)/85.8" x 29.2" x 63.4"
Packing Size	2300x650x1090(mm)/90.6" x 25.6" x43"
40HQ	36Sets



RE930
ELLIPTICAL



RE700
ELLIPTICAL



RE500
ELLIPTICAL

Model	RE700	RE500
Certification	CE,ETL,EN957	CE,ETL,EN957
Max User Weight	160kg/352lbs	160kg/352lbs
Brake Type	Self Powered Hybrid Brake	Self Powered Hybrid Brake
Resistance Brake Power	350W	350W
Resistance Levels	20 Levels	20 Levels
Electrical Receptacle & Plug	No	No
Incline range	No	No
Stride Length	533mm/21"	533mm/21"
Pedal	Pedal with cushioned gel pads	Pedal with cushioned gel pads
Pedal Spacing	1"	1"
Step-up Height	190mm/7.5"	190mm/7.5"
One Touch Buttons	No	No
Handle bar Control	Yes	Yes
Console Display	7 windows + dot Matrix	7 windows + dot Matrix
Console Readouts	Speed,Time,Calorie,RPM,Distance,Heart rate,Resistance,etc.	Speed,Time,Calorie,RPM,Distance,Heart rate,Resistance,etc.
Metric/English	Metric&English	Metric&English
Touch Screen	No	No
Entertainment (TV, Wifi etc.)	No	No
Programs	11	11
HR Monitor	Contact&Telemetry	Contact&Telemetry
Accessory Storage	Cup holder, Magazine Holder, Phone Holder	Cup holder, Magazine Holder, Phone Holder
USB Charger	No	No
USB Data Exchange	No	No
Multi-language Display	No	No
Special Features	On-your-finger-tips, Ergonomically designed handle bars, Easy to service	On-your-finger-tips, Ergonomically designed handle bars, Easy to service
Gross Weight	174.5kg/383.9lbs	175.4kg/385.9lbs
Net Weight	118.1kg/259.8lbs	119.4kg/262.7lbs
Product Dimension	2179x742x1610(mm)/85.8" x 29.2" x 63.4"	2179x742x1610(mm)/85.8" x 29.2" x 63.4"
Packing Size	2220x650x1090(mm)/87.4" x 25.6" x43"	2220x650x1095(mm)/87.4" x 25.6" x43.1"
40GP	36Sets	36Sets

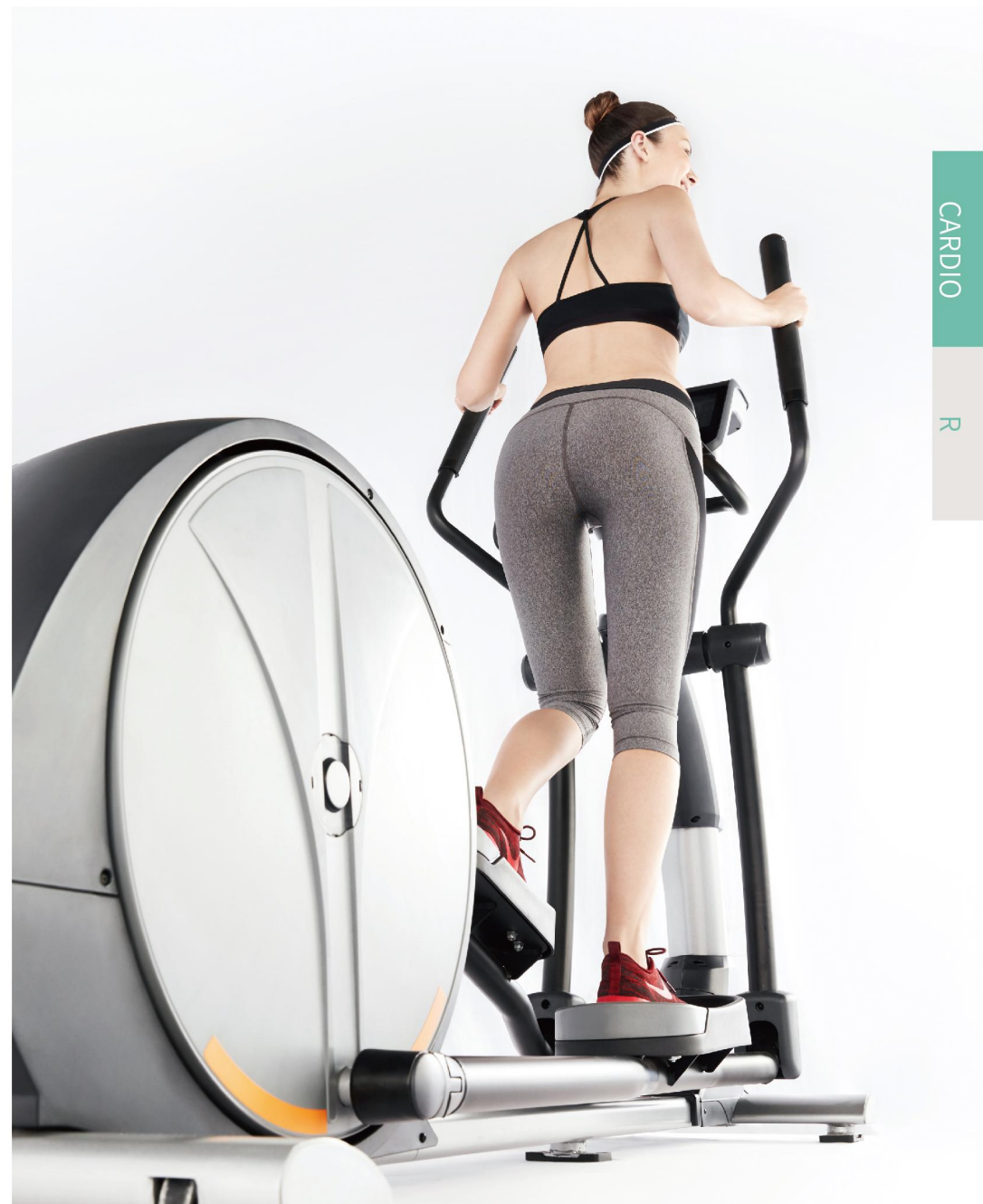

P Series



Model	PT500
Certification	CE
Max User Weight	150kg/330lbs
AC/DC	AC
Power Requirement	15A
Electrical Receptacle & Plug	220-240V
Motor Power	3HP
Motor Peak Power	4.5HP
Speed range	1-20km/h (0.6-12mph)
Incline range	0-15%
One Touch Buttons	3%,6%,9%,12%(incline);3,6,9,12(speed)
Handle bar Control	No
Console Display	18.5" TFT
Console Readouts	Heart rate,Time Elapsed, Calories, Distance, Speed, incline, 1/4 mile or 400 meters motivational track
Metric/English	Metric&English
Touch Screen	Yes
Entertainment (TV, WiFi etc.)	Music/TV (cable) /WiFi/Internet/Virtual Scenery
Programs	Cardio,Random,Fatburn,Hills,Interval,HR,5km, Firemantest.
HR Monitor	Contact&Telemetry
Roller Diameter	Front:88.9mm(3.5") Back:76mm (3")
Deck	Reversable 1"deck
Running surface	545x1524(mm)/21.5"x 60"
Belt Thickness	2.5mm
Belt Brand	Siegling
Step-up Height	260mm
Suspension System	Pullflex™ Commercial Suspension System
Accessory Storage	Phone Holder/ 2 Bottle Holders
USB Charger	No
USB Data Exchange	No
Fan	Yes (3 speed level)
Multi-language Display	Yes
Gross Weight	270kg/594lbs
Net Weight	208kg/457.6lbs
Product Dimension	2140x935x1480(mm)/84.3"x36.8"x 58.3"
Packing size	2 Packages: Box 1:2260×930×550(mm)/89"×36.6"×21.7" Box 2:1265×1050×350(mm)/49.8"×41.3"×13.8"
40HQ	41Sets
40GP	36Sets



PT500
TREADMILL



PT400
TREADMILL



PT300
TREADMILL

Model	PT400	PT300
Certification	CE	CE,ETL,EN957
Max User Weight	180kg/396lbs	150kg/330lbs
AC/DC	AC	AC
Power Requirement	15A	15A
Electrical Receptacle & Plug	220-240V	220-240V
Motor Power	4HP	3HP
Motor Peak Power	6HP	4.5HP
Speed range	1-25km/h (0.6-15mph)	1-20km/h (0.6-12mph)
Incline range	0-15%	0-15%
One Touch Buttons	2%,4%,6%,8%,10%,12%(incline), 2,4,6,8,10,12(Speed)	2%,4%,6%,8%,10%,12%(incline), 2,4,6,8,10,12(Speed)
Handle bar Control	No	No
Console Display	7"LCD	6 LED + Matrix 16×40
Console Readouts	Heart rate, Time Elapsed, Calories, Distance, Speed, incline,1/4 mile or 400 meters motivational track	Heart rate, Time Elapsed, Calories, Distance, Speed, incline,1/4 mile or 400 meters motivational track
Metric/English	Metric&English	Metric&English
Touch Screen	No	No
Entertainment (TV, Wifi etc.)	No	No
Programs	5 Preset, 3 Targets, 2 User, 3 HR	5 Preset, 3 Targets, 2 User, 3 HR
HR Monitor	Contact&Telemetry	Contact&Telemetry
Roller Diameter	Front:76mm (3") Back:76mm (3")	Front:88.9mm (3.5") Back:76mm (3")
Deck	Reversible 1"deck	Reversible 1"deck
Running surface	508x1524(mm) / 20"x60"	545x1524(mm)/21.5"x 60"
Belt Thickness	3.3mm	2.5mm
Belt Brand	Siegling	Siegling
Step-up Height	260mm	260mm
Suspension System	Pulflex™ Commercial Suspension System	Pulflex™ Commercial Suspension System
Accessory Storage	IPAD, Phone Holder, Magazine Holder, 2 Bottle Holders	IPAD, Phone Holder, Magazine Holder, 2 Bottle Holders
USB Charger	No	No
USB Data Exchange	No	No
Fan	Yes (3 speed level)	Yes (3 speed level)
Multi-language Display	No	No
Gross Weight	281kg/618.2lbs	263.3kg/579.3lbs
Net Weight	216.6kg/476.5lbs	211.1kg/464.4lbs
Product Dimension	2140x935x1480(mm)/84.3"x36.8"x 58.3"	2140x935x1480(mm)/84.3" x36.8" x 58.3"
Packing Size	2 Packages: Box 1:2260×930×550(mm) 89"×36.6"×21.7" Box 2:1265×1050×320(mm) 49.8"×41.3"×12.6"	2 Packages: Box 1:2260×930×550(mm) 89"×36.6"×21.7" Box 2:1265×1050×350(mm) 49.8"×41.3"×13.8"
40HQ	41Sets	41Sets
40GP	36Sets	36Sets



PU300
UPRIGHT BIKE



PR300
RECUMBENT BIKE



PE350
ELLIPTICAL



PST300
STEPPER

Model	PU300	PR300
Certification	CE	CE
Max User Weight	160kg/352lbs	160kg/352lbs
Brake Type	Self Powered Hybrid Brake	Self Powered Hybrid Brake
Resistance Brake Power	350W	350W
Resistance Levels	20	20
Crank	Standard	Standard
Pedal	Weighted pedal with skate-style clip	Weighted pedal with skate-style clip
Flywheel Weight	8kg	8kg
One Touch Buttons	No	No
Handle bar Control	3 riding positions , with contact heart rate grips	Ergonomically designed seat-side handles with contact heart rate
Console Display	3window +dot matrix	3window +dot matrix
Console Readouts	distance, time, speed, watt, calories, calories/hours, mets, RPM, heart rate	distance, time, speed, watt, calories, calories/hours, mets, RPM, heart rate
Metric/English	Metric&English	Metric&English
Touch Screen	No	No
Entertainment (TV, Wifi etc.)	No	No
Programs	11	11
HR Monitor	Contact&Telemetry	Contact&Telemetry
Accessory Storage	Yes	Yes
USB Charger	No	No
USB Data Exchange	No	No
Multi-language Display	No	No
Special Features	Walk-through design	Walk-through design
Gross Weight	74.8kg/164.6lbs	108kg/237.6lbs
Net Weight	59.5kg/130.9lbs	85kg/187lbs
Product Dimension	1260x675x1435mm/49.6"x26.6"x56.5"	1651x675x1403(mm)/65"x26.6"x55.3"
Packing Size	2 Packages: Box 1:1230×220×840(mm)48.5"×8.7"×33" Box 2:585×575×235(mm)23"×22.3"×9.3"	2 Packages: Box 1:1645×250×820(mm)/64.8"×9.9"×32.3" Box 2:685×675×530(mm)/27"×26.5"×20.9"
40HQ	215Sets	112Sets

Model	PE350	PST300
Certification	CE	CE
Max User Weight	150kg/330lbs	150kg/330lbs
Brake Type	Self Powered Hybrid Brake	Self Powered Hybrid Brake
Resistance Brake Power	350W	400W
Resistance Levels	20 Levels	20 Levels
Electrical Receptacle & Plug	No	No
Incline range	No	No
Stride Length	508mm/20"	No
Pedal	Pedal with cushioned gel pads	Pedal with cushioned gel pads
Pedal Spacing	85mm/3.3"	82mm/3.2"
Step-up Height	210mm/8.3"	330mm/13"
One Touch Buttons	No	No
Handle bar Control	Yes	Yes
Console Display	3window +dot matrix	3window +dot matrix
Console Readouts	Distance, time, speed, watt, calories, calories/hours, mets, RPM, heart rate	Distance, time, speed, watt, calories, calories/hours, mets, RPM, heart rate
Metric/English	Metric&English	Metric&English
Touch Screen	No	No
Entertainment (TV, Wifi etc.)	No	No
Programs	11	11
HR Monitor	Contact&Telemetry	Contact&Telemetry
Accessory Storage	Cup holder, Magazine Holder, Phone Holder	Cup holder, Magazine Holder, Phone Holder
USB Charger	No	No
USB Data Exchange	No	No
Multi-language Display	No	No
Special Features	On-your-finger-tips, Ergonomically designed handle bars	On-your-finger-tips, Ergonomically designed handle bars, INA clutch
Gross Weight	191.7kg/421.7lbs	118kg/259.6lbs
Net Weight	124kg/272.8lbs	96kg/211.2lbs
Product Dimension	2110x650x1640(mm)/83.1"x25.6"x 64.6"	1265x885x1650(mm)/49.8"x34.9"x 65"
Packing Size	2015x710x1165(mm)/79.4"x 28"x45.9"	1185x910x760(mm)/46.7"x 35.8"x30"
40GP	33Sets	67Sets



● ECT7
TREADMILL

● ECE7
ELLIPTICAL

● ECR7
RECURBENT BIKE

● ECU7
UPRIGHT BIKE

● ES3000
3 STACK MULTI-STATION
● ES3000 OPT
HI-LO PULLEY ATTACHMENT

● ES9030
DUAL ADJUSTABLE PULLEY
● ES7011
BENCH

ENCORE

The Complete Series

Space Solutions for Corporate Fitness

ECT7 TREADMILL



Built in bottle holders, accessories tray on both sides and display rack.



Ergonomically designed handle bars with a towel rail.



User-friendly console with keypad and scrolling LED window, multiple workout programs and unique heart rate zone programs.



Bright orange colored staddle cover trim for step-on and step-off safety.

Model	ECT7
Max User Weight	160kg/352lbs
AC/DC	AC
Power Requirement	15A
Electrical Receptacle & Plug	220-240V
Motor Power	3HP
Motor Peak Power	4.5HP
Speed range	1-20km/h (0.6-12mph)
Incline range	0 to 15%
One Touch Buttons	3%,6%,9%,12%(incline),3,6,9,12(Speed)
Handle bar Control	Yes
Console Display	6 window + dot Matrix
Console Readouts	Heart rate, Time Elapsed, Calories, Distance, Speed, incline, 1/4 mile or 400 meters motivational track
Metric/English	Metric&English
Touch Screen	No
Entertainment (TV, Wifi etc.)	No
Programs	Target,Manual,Cardio, Interval, Burn Calories, Heart Rate, 5K, Hill, Advanced
HR Monitor	Contact&Telemetry
Roller Diameter	Front:76mm (3") Back:63.8mm (2.5")
Deck	Reversible 1"deck
Running surface	508x1524(mm)/20"x 60"
Belt Thickness	2.5mm
Belt Brand	Siegling
Step-up Height	224mm
Suspension System	Pulflex™ Commercial Suspension System
Handle bar Control	Yes
Handle Folding	No
Accessory Storage	IPAD, Phone Holder, Magazine Holder, 2 Bottle Holders
USB Charger	No
USB Data Exchange	No
Fan	Yes (3 speed level)
Multi-language Display	No
Net Weight	213.6kg/469.9lbs
Gross Weight	150.2kg/330.4lbs
Product Dimension	2045x940x1455mm/80.5"x37"x 57.3"
Packing Size	2 Packages: Box 1:2215×850×475(mm) 87.2"×33.5"×18.7" Box 2:1045×855×410(mm) 41.1"×33.7"×16.1"
40HQ	54Sets



User-friendly console with keypad and scrolling LED window, multiple workout programs and unique heart rate zone programs.



Multi grip ergo handles provide users of varying heights difference workout experiences.



Ergonomically correct pedals provide the ultimate natural motion.



User-friendly mini step allows users to step on and off from the rear.



Easy to service shroud design allows for convenient maintenance.



Infinitely adjustable incline provides a dynamic and motivational workout experience.



ECE7
ELLIPTICAL



ECE5
ELLIPTICAL



Model	ECE7	ECE5
Certification	CE	CE
Max User Weight	150kg/330lbs	150kg/330lbs
Power Supply	150W	
Brake Type	Magnetic	Self Powered Hybrid Brake
Resistance Brake Power	300W	350W
Resistance Levels	20 Levels	20 Levels
Electrical Receptacle & Plug	Yes	No
Incline range	11%(0-20°)	No
Stride Length	508mm/20"	508mm/20"
Pedal	Pedal with cushioned gel pads	Pedal with cushioned gel pads
Pedal Spacing	75mm/2.95"	75mm/2.95"
Step-up Height	225mm/8.86"	250mm/9.84"
One Touch Buttons	No	No
Handle bar Control	Yes	Yes
Console Display	6 LED windows + dot Matrix LED	6 LED windows + dot Matrix LED
Console Readouts	Speed, Time, Calorie, RPM, Distance, Heart rate, Resistance, incline, etc.	Speed, Time, Calorie, RPM, Distance, Heart rate, Resistance, etc.
Metric/English	Metric&English	Metric&English
Touch Screen	No	No
Entertainment (TV, Wifi etc.)	No	No
Programs	8 Preset, 4 Targets, 4 User	8 Preset, 4 Targets, 1 User
HR Monitor	Contact&Telemetry	Contact&Telemetry
Accessory Storage	Cup holder, Magazine Holder, Phone Holder	Cup holder, Magazine Holder, Phone Holder
USB Charger	No	No
USB Data Exchange	No	No
Multi-language Display	No	No
Net Weight	179.2kg/394.2lbs	162.2kg/356.8lbs
Gross Weight	133.5kg/293.7lbs	119.6kg/263.1lbs
Product Dimension	1765x815x1800(mm)/70"x 32"x 70"	1765x815x1800mm/70"x 32"x 70"
Packing Size	1150x765x1110(mm)/45.3"x 30"x 43.7"	1150x765x1110mm/45.3"x 30"x 43.7"
40HQ	60Sets	60Sets

ECR7 RECUMBENT BIKE



Model	ECR7
Certification	CE
Max User Weight	150kg/330lbs
Brake Type	Self-generating
Resistance Brake Power	300W
Resistance Levels	20
Crank	Standard
Pedal	Weighted pedal with skate-style clip
Flywheel Weight	8kg
One Touch Buttons	No
Handle bar Control	Ergonomically designed seat-side handles with contact heart rate
Console Display	6 LED windows + dot Matrix LED
Console Readouts	Speed,Time,Calorie,RPM,Distance,Heart rate,Resistance,etc.
Metric/English	Metric&English
Touch Screen	No
Entertainment (TV, Wifi etc.)	No
Programs	12
HR Monitor	Contact&Telemetry
Accessory Storage	Yes
USB Charger	No
USB Data Exchange	No
Multi-language Display	No
Special Features	On-your-finger-tips, ergonomically designed handle bars, two-sided pedals, k-o-p-s biomechanics, easy to service
Gross Weight	100.7kg/221.54lbs
Net Weight	83.2kg/183.0lbs
Product Dimension	1670x634x1326mm/66"x 25"x 52"
Packing Size	1775x445x730mm/70"x 17.5"x 28.8"
40GP	96Sets



User-friendly console with keypad and scrolling LED window, multiple workout programs and unique heart rate zone programs.



Multiple riding grip positions are fitted with two sets of heart-rate reception, which provides users different workout experience. Bright colored fingertip controls for changing resistance for easy adjustments throughout the workout.



Dual oversized water bottle holders and mobile phone pocket conveniently located for those long bike rides.



Ergonomic single-hand seat adjustment makes easy to find the right position.



Easy to service shroud design allows for convenient maintenance.



ECU7 UPRIGHT BIKE

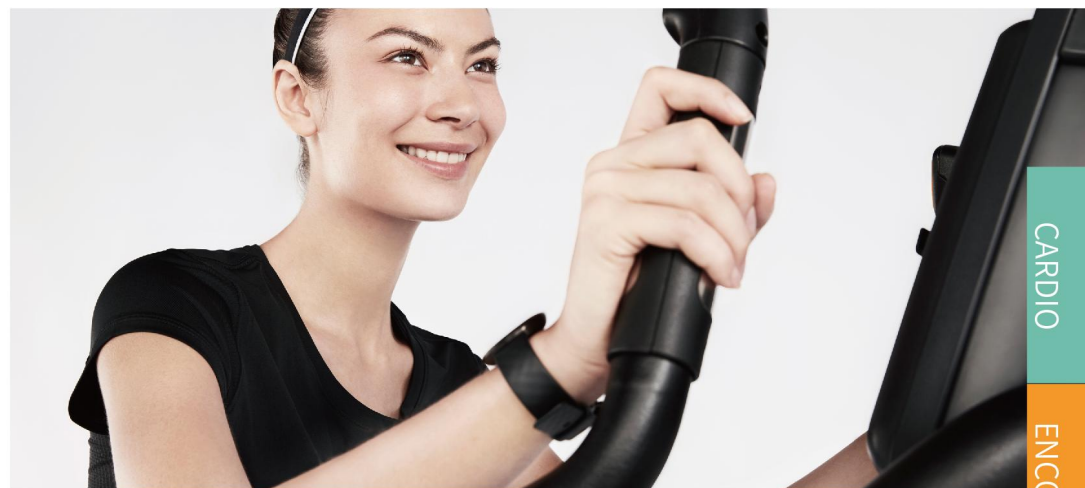

Model	ECU7
Certification	CE
Max User Weight	150kg/330lbs
Brake Type	Self-generating
Resistance Brake Power	300W
Resistance Levels	20
Crank	standard
Pedal	Weighted pedal with skate-style clip
Flywheel Weight	8kg
One Touch Buttons	No
Handle bar Control	3 riding positions , with contact heart rate grips
Console Display	6 LED windows +dot Matrix LED
Console Readouts	Speed,Time,Calorie,RPM,Distance,Heart rate,Resistance,etc.
Metric/English	Metric&English
Touch Screen	No
Entertainment (TV, Wifi etc.)	No
Programs	12
HR Monitor	Contact&Telemetry
Accessory Storage	Yes
USB Charger	No
USB Data Exchange	No
Multi-language Display	No
Special Features	On-your-finger-tips, ergonomically designed handle bars, two-sided pedals, k-o-p-s biomechanics, easy to service
Gross Weight	78.5kg/172.7lbs
Net Weight	67.4kg/148.3lbs
Product Dimension	1140x635x1480(mm)/44.9"x 25"x 58.3"
Packing Size	1155x445x730(mm)/45.5"x 17.5"x 28.8"
40GP	156Sets



AC3170
TREADMILL



AC2970
TREADMILL



Model	AC3170	AC2970
Certification	CE	CE,UL,EN957
Max User Weight	180kg/396lbs	170kg/374lbs
AC/DC	AC	AC
Power Requirement	15A	15A
Electrical Receptacle & Plug	220-240V	220-240V
Motor Power	4HP	3HP
Motor Peak Power	6HP	4.5HP
Speed range	1-25km/h (0.6-15mph)	1-20km/h (0.6-12mph)
Incline range	0-15%	0-15%
One Touch Buttons	2%, 4%, 6%, 8%, 10%, 12%(Incline); 2,4,6,8,10,12(Speed)	2%, 4%, 6%, 8%, 10%, 12%(Incline); 2,4,6,8,10,12(Speed)
Handle bar Control	No	No
Console Display	5 LED + Matrix 16×80	4 LED + Matrix 8×16
Console Readouts	Heart rate,Time Elapsed, Calories, Distance, Speed,Incline, 1/4 mile or 400 meters motivational track	Heart rate,Time Elapsed, Calories, Distance, Speed,Incline, 1/4 mile or 400 meters motivational track
Metric/English	Metric/English	Metric/English
Touch Screen	No	No
Entertainment (TV, WiFi etc.)	No	No
Programs	5 Preset, 3 Targets, 2 User, 3 HR	5 Preset, 3 Targets, 2 User, 3 HR
HR Monitor	Contact&Telemetry	Contact&Telemetry
Roller Diameter	Front:101m (4") Back:90mm (3.5")	Front:76mm (3") Back:76mm (3")
Deck	Reversable 1"Deck	1"Deck
Running surface	520×1550(mm) / 20.5"× 61"	558×1524(mm) / 22"× 60"
Belt Thickness	3.3mm	2.5mm
Belt Brand	Siegling	Siegling
Step-up Height	240mm	252mm
Suspension System	Pullflex™ Commercial Suspension System	Pullflex™ Commercial Suspension System
Accessory Storage	IPAD/Phone Holder/Magazine Holder 2 Bottle Holders	Phone Holder/ 2 Bottle Holders
USB Charger	No	No
USB Data Exchange	No	No
Fan	Yes (3 speed level)	No
Multi-language Display	No	No
Gross Weight	293.7kg/646.1lbs	239.7kg/527.3lbs
Net Weight	215kg/473lbs	170.3kg/374.7lbs
Product Dimension	2250×910×1610(mm)/88.6"×35.9"×63.4"	2180×900×1410(mm)/85.9"×35.5"×55.5"
Packing size	2220×970×780(mm)/87.4"×38.2"×30.8"	2320×930×630(mm)/91.3"×36.6"×24.8"
40HQ		48Sets
40GP	35Sets	36Sets

A woman with dark hair pulled back, wearing a black sports top and a white headband, is riding a stationary bike. She is looking upwards and to the right with a slight smile. The bike's black frame and handlebars are visible in the foreground. The background is a plain, light-colored wall.

INDOOR GROUP CYCLE



CARDIO
INDOOR CYCLE

PS450 INDOOR GROUP CYCLE

Resistance System	Magnetic
Emergency Stop	Push
Flywheel	Aluminum
Flywheel Weight	3.5kg
Pulley	Aluminum
Drivetrain	Belt
Drivetrain Ratio	1:10
Frame Material	Steel
Adjustment Type	Aluminum
Pedal	Dual-sided vp pedal
Shaft	φ25
Bearing	TPI
Handlebar	Multi-position, Soft PVC
Handlebar Adjustment	Vertical&Horizontal
Saddle	Ultra-padded sport saddle
Saddle Adjustments	Vertical&Horizontal
Water Bottle Holder	Double
Maximum User Weight	150kgs/330lbs
Gross Weight	54kg/118.8lbs
Net Weight	47kg/103.4lbs
Product Dimension	1445×604×1050(mm) 56.9"×23.8"×41.3"
Packing size	1250×315×1000(mm) 49"×12.4"×39.3"



Option: Console

Resistance Level	1-20
Metric/English	Metric/English
Console Readouts	Resistance Level, Time, Speed(AVG/MAX), Distance, Watt(AVG/MAX), RPM(AVG/MAX), Heart Rate(AVG/MAX), Calories
Console Display	4.5"LCD
Power Requirement	5# battery×4
Product Dimension	160×78×30.5 (mm)



Magnetic brake system provides more stable resistance, and more convenient adjustment.



V structure, 164mm Q-FACTOR allows ideal riding position



Seat and handles are adjustable horizontally and vertically. Aluminum post and newly designed knob allows convenient adjustment



Dual cup holders for intense training



Rear aluminum flywheel is waterproof. The plastic edge shroud ensures riding safety.



Dual-sided pedals allow riders to wear either cycling or athletic shoes.



Tension unit for stretch before and after riding



Larger main frame, over-sized axis and pedal shaft ensure reliable quality.



CARDIO
INDOOR CYCLE



Handlebar
Vertically adjustable with nice hand feeling. Multiple handle positions can meeting various training needs.



Brake
Reliable Nylon nob brake. Coated steel cup holder is easy to access.



Seat
Precision casting seat part combined with chromium-plated steel adjusting tube make it easy to adjust position. Ergonomic seat pad provides comfortable training.



Resistance
Long-lasting pedals and classic fly wheel driving system brings nice training experience to users.



Frame
Double-oval tube and anti-rust steel frame makes extraordinary appearance.



CONSOLE



PS300



PS303



PS300 SPIN BIKE

Dimension(L×W×H)	1202×528×1110 (mm)
Product Weight	65kg
Max User Weight	150kg



STRENGTH

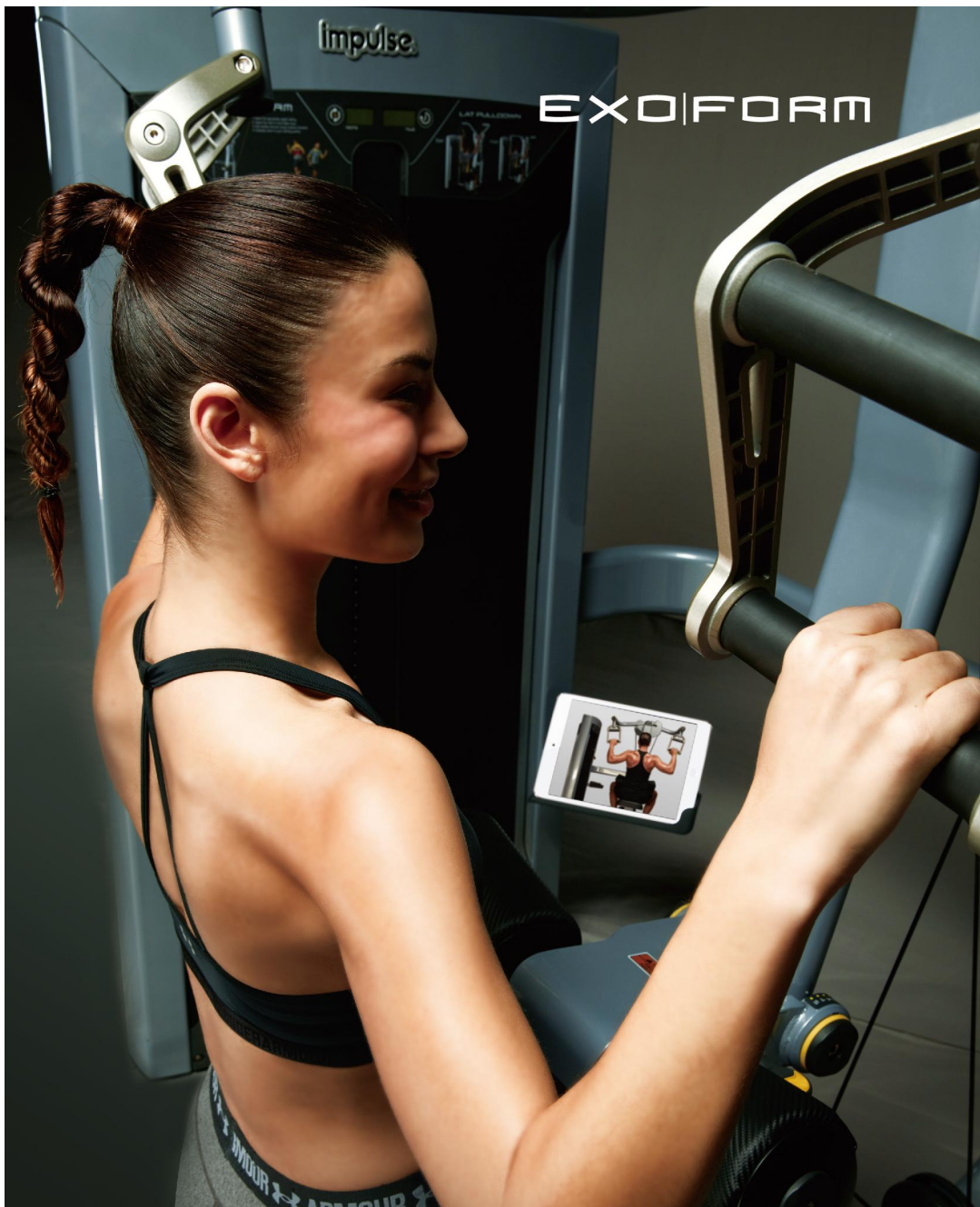

EXOFORM

EXOFORM >>>

Uniformly low profile at 1492mm is designed by American team. Translucent shroud at thickness 3.2mm with smooth pattern is in injection molding, which designed elegantly and ensures ultra durability and non-deformation

Build-in console, which is well designed by American UI team, displays reps and time

The upright tubes are with special tube at size 72.8×141.7×3mm, and the functional part with race track tube at size 40×133×3mm. Tubes apply double powder-coated & painting process which ensure high-quality and ultra durability

The steel guide rod (diameter:19mm) is anti-corrosion coated and polished which ensures smoothly travel and rust-proof

Friendly designed iPad and bottle holders are separated to meet various requirement

The 5LBS incremental weight is to meet users requirement

Weight stack: 19mm full steel plate. Weight options-160/200/235/295Lbs

All the hardware parts exposed are nickel plated or stainless steel. The NBK bearing is applied

Ergonomically designed handle bars, which is patented, are with TPU material and aluminium grip ring. The concise design offers comfort and safety

Ergonomically designed upholstery is with PU foam which offers comfort and safety protection

Belt and cable driving system are both applied. Self-lubricate American Loss cable with nylon-coated 12 complex fiber ensures service life 300,000 times. The belt is with steel wire embedded which ensures ultra durability and long lifetime

All dynamic components are shielded for safety purpose
Gas spring for resetting

With spiral spring assistance system, the patented 3-linkage seat adjustment is concisely designed, cost-saving and offers easy installment



Meet EN957 safety regulation



FE9701 CHEST PRESS

Dimension (L×W×H)	1230x1570x1490(mm) 48.4x61.8x58.7 (in)
Net Weight	169.7kg/373.3lbs



FE9702 LAT PULLDOWN

Dimension (L×W×H)	1305×1230×2010 (mm) 51.4x48.4x79.1 (in)
Net Weight	177.7kg/390.9lbs

FE9703 ARM CURL

Dimension (L×W×H)	1150x1567x1490(mm) 45.3x61.7x58.7 (in)
Net Weight	169.1kg/372lbs



FE9704 PECTORAL

Dimension (L×W×H)	1147x1551x1490 (mm) 45.2x61.1x58.7 (in)
Net Weight	131kg/288.2lbs (TBD)

STRENGTH
EXOFORM



FE9705 LEG EXTENSION

Dimension (L×W×H)	1300x1240x1490(mm) 51.2x48.8x58.7 (in)
Net Weight	169.6kg/373.1lbs



FE9706 SEATED LEG CURL

Dimension (L×W×H)	1242x1541x1490 (mm) 48.9x60.7x58.7 (in)
Net Weight	183.6kg/403.9lbs



FE9710 LEG PRESS

Dimension (L×W×H)	1785×1350×1490 (mm) 70.3x53.1x58.7 (in)
Net Weight	279kgs/613.8lbs



FE9708 ABDUCTOR/ADDUCTOR

Dimension (L×W×H)	1736x1500x1490 (mm) 68.3x59.1x58.7 (in)
Net Weight	165.8kg/364.8lbs



STRENGTH
EXOFORM



FE9712 SHOULDER PRESS

Dimension (L×W×H)	1765x1425x1490(mm) 69.5x56.1x58.7 (in)
Net Weight	168.7kg/371.1lbs



FE9714 ABDOMINAL

Dimension (L×W×H)	1385×1210×1490 (mm) 54.5x47.6x58.7 (in)
Net Weight	141.5kg/311.3lbs



FE9715 PEC FLY/REAR DELT

Dimension (L×W×H)	1296x1758x1490(mm) 51x69.2x58.7 (in)
Net Weight	160.7kg/353.5lbs



FE9716 CALF RAISE

Dimension (L×W×H)	1265x1186x1721(mm) 49.8x46.7x67.8 (in)
Product Weight	167.8kg/369.2lbs

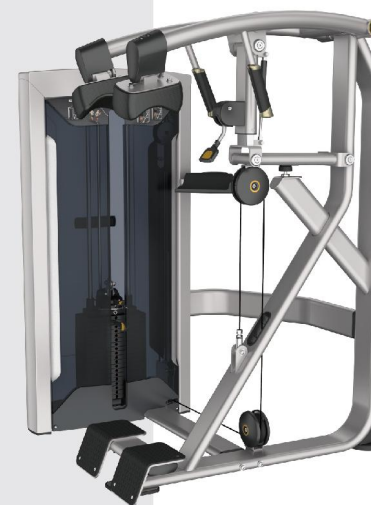



FE9718 TORSO ROTATION

Dimension (L×W×H)	1291x1346x1490 (mm) 50.8x53.0x58.7 (in)
Net Weight	138.5kg/304.7lbs (TBD)

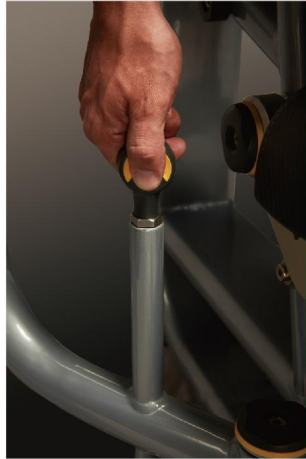

FE9720 WEIGHT ASSISTED CHIN/DIP COMBO

Dimension (L×W×H)	1750x1380x2200 (mm) 68.9x54.3x86.6 (in)
Net Weight	243.5kg/535.7lbs



FE9719 ROW

Dimension (L×W×H)	2000x1130x1490(mm) 78.7x44.5x58.7 (in)
Net Weight	174.8kg/384.6lbs



FE9721 PRONE LEG CURL

Dimension (L×W×H)	1705x1194x1490(mm) 67.1x47x58.7 (in)
Net Weight	154.2kg/339.2lbs



FE9723 TRICEP

Dimension (L×W×H)	1150x1580x1490(mm) 45.3x62.2x58.7 (in)
Net Weight	163.5kg/359.7lbs



FE9724 LATERAL RAISE

Dimension (L×W×H)	1261x1267x1490 (mm) 49.6x25.5x58.7 (in)
Net Weight	187.5kg/412.5lbs



FE9726 GLUTE

Dimension (L×W×H)	1304x1484x1490 (mm) 51.3x58.4x58.7 (in)
Net Weight	100kg/220lbs (TBD)



FE9732 BACK EXTENSION

Dimension (L×W×H)	1385x1225x1490(mm) 54.5x48.2x58.7 (in)
Net Weight	185.4kg/407.9lbs



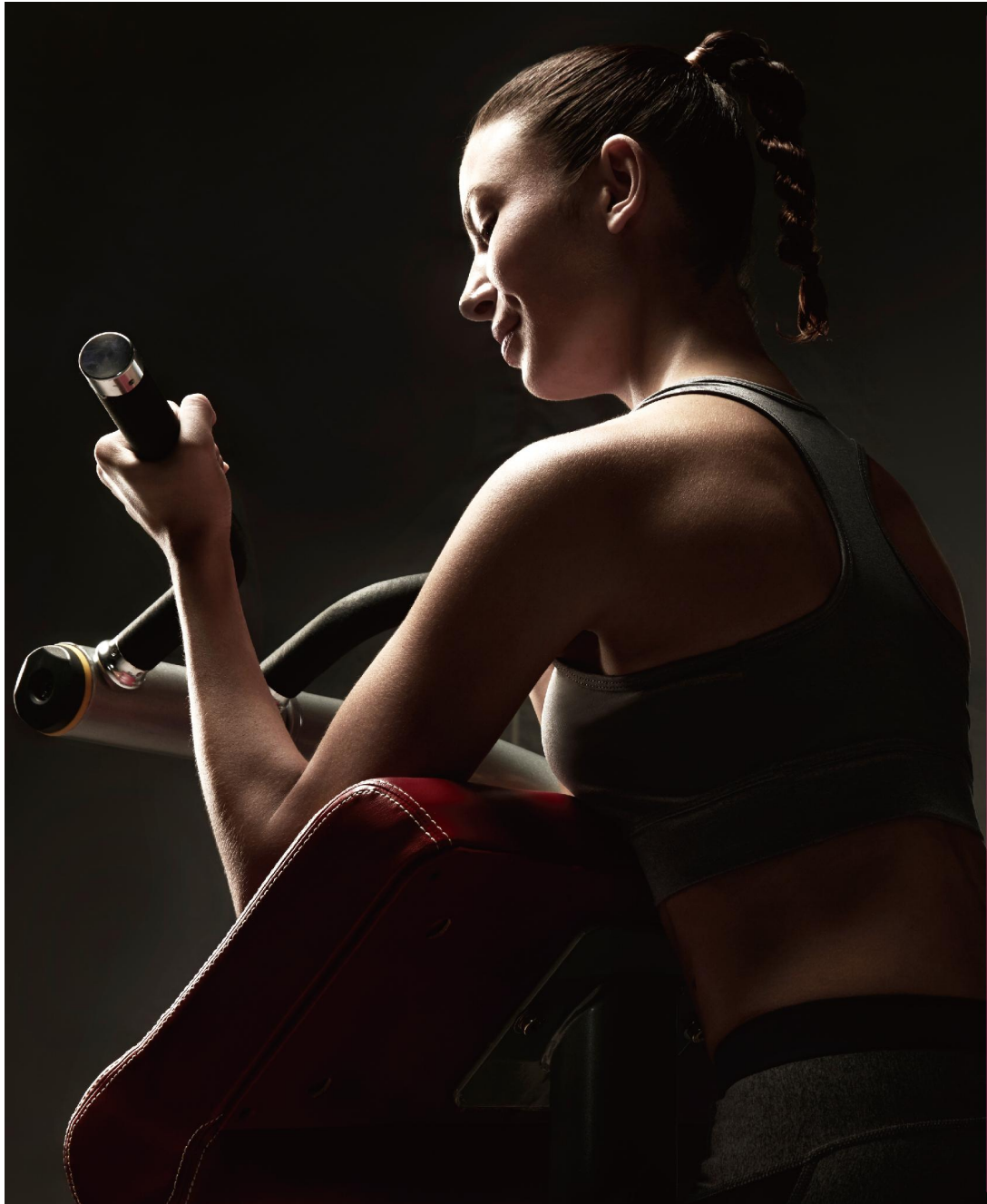

IT95 Line >>>

Tube: 3mm tube in main frame and movement parts. U-frame uses PR95x81.1x3 tube and functional parts use RT50x100

Plastic part: Injection molding for better quality

Painting: Double coated surface treatment

Incremental weight (optional): 5lbs for smaller adjustment

Weight stack: 19mm full steel plate. Weight options - 160/200/235/295Lbs

Easy to enter and exit the machine and able to adjust when in sitting position

Conform with EN957. Passed 300,000 times fatigue test and 100kg stable test

Handle: Patented ergonomic design with TPU material

Standard metal part: Nickel plated or stainless steel for better appearance and quality

Diverging motion structure allows the arm training simultaneously and alternately

Pad: Double stitch and add protect cover on the back. Various colors to choose from

Pulley: Lathed pulley with less tolerance

Cable: USA imported cable which passed more than 250 thousand times test

Bearing: Reliable Taiwan brand

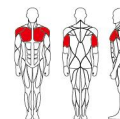

IT9501 CHEST PRESS

PRODUCT DIMENSION (LxWxH)	1475x1200x1506 (mm) 58.1x47.2x59.3 (in)
PRODUCT WEIGHT	127.4kg/280.3lbs

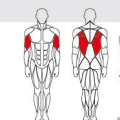

IT9502 LAT PULLDOWN

PRODUCT DIMENSION (LxWxH)	1437x1380x1889 (mm) 56.6x54.3x74.4 (in)
PRODUCT WEIGHT	147.7kg/324.9lbs

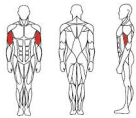

IT9503 ARM CURL

PRODUCT DIMENSION (LxWxH)	1295x1208x1506 (mm) 51.1x47.6x59.3 (in)
PRODUCT WEIGHT	115.5kg/254.1lbs

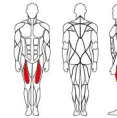

IT9505 LEG EXTENSION

PRODUCT DIMENSION (LxWxH)	1202x1189x1506 (mm) 47.3x46.8x59.3 (in)
PRODUCT WEIGHT	133.1kg/292.8lbs

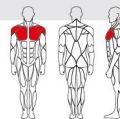

IT9504 PECTORAL

PRODUCT DIMENSION (LxWxH)	1460x1360x1506 (mm) 57.5x53.5x59.3 (in)
PRODUCT WEIGHT	145.2kg/319.4lbs

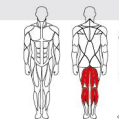

IT9506 SEATED LEG CURL

PRODUCT DIMENSION (LxWxH)	1536x1186x1506 (mm) 60.5x46.7x59.3 (in)
PRODUCT WEIGHT	149.6kg/329.1lbs

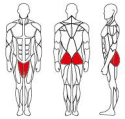

IT9508 ABDUCTOR/ADDUCTOR

PRODUCT DIMENSION (LxWxH)	1555x900x1506 (mm) 61.2x35.4x59.3 (in)
PRODUCT WEIGHT	131.1kg/288.4lbs

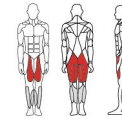

IT9510 LEG PRESS

PRODUCT DIMENSION (LxWxH)	1800x1200x1506 (mm) 70.9x47.2x59.3 (in)
PRODUCT WEIGHT	211.3kg/464.9lbs

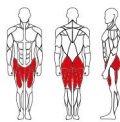

IT9509 TOTAL HIP

PRODUCT DIMENSION (LxWxH)	1292x972x1506 (mm) 50.9x38.3x59.3 (in)
PRODUCT WEIGHT	148.2kg/326.7lbs

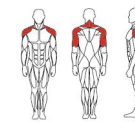

IT9512 SHOULDER PRESS

PRODUCT DIMENSION (LxWxH)	1560x1443x1510 (mm) 61.4x56.8x59.4 (in)
PRODUCT WEIGHT	137.4kg/302.3lbs

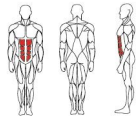

IT9514 ABDOMINAL

PRODUCT DIMENSION (LxWxH)	1346x1148x1581 (mm) 53x45.2x62.2 (in)
PRODUCT WEIGHT	116.2kg/255.6lbs

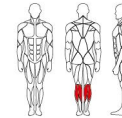

IT9516 CALF RAISE

PRODUCT DIMENSION (LxWxH)	1287x1156x1739 (mm) 50.7x45.5x68.5 (in)
PRODUCT WEIGHT	120.2kg/264.4lbs

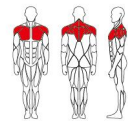

IT9515 PEC FLY/REAR DELT

PRODUCT DIMENSION (LxWxH)	1180x1288x2048 (mm) 46.5x50.7x80.6 (in)
PRODUCT WEIGHT	124.0kg/272.8lbs

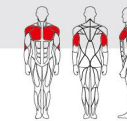

IT9517 DIP PRESS

PRODUCT DIMENSION (LxWxH)	1694x1234x1506 (mm) 66.7x48.6x59.3 (in)
PRODUCT WEIGHT	142.5kg/313.5lbs

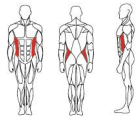

IT9518 TORSO ROTATION

PRODUCT DIMENSION (LxWxH)	1225x1205x1506 (mm) 48.2x47.4x59.3 (in)
PRODUCT WEIGHT	127.3kg/280.1lbs

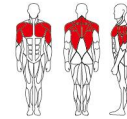

IT9520 WEIGHT ASSISTED CHIN/DIP COMBO

PRODUCT DIMENSION (LxWxH)	1573x1315x2286 (mm) 61.9x51.8x90 (in)
PRODUCT WEIGHT	171kg/376.2lbs

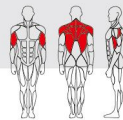

IT9519 VERTICAL ROW

PRODUCT DIMENSION (LxWxH)	1622x1300x1506 (mm) 63.9x51.2x59.3 (in)
PRODUCT WEIGHT	126.5kg/278.3lbs

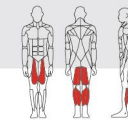

IT9521 PRONE LEG CURL

PRODUCT DIMENSION (LxWxH)	1443x1146x1506 (mm) 56.8x45.1x59.3 (in)
PRODUCT WEIGHT	131.5kg/289.3lbs

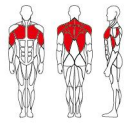

**IT9522
LAT PULLDOWN/VERTICAL ROW**

PRODUCT DIMENSION (LxWxH)	1900x900x2230 (mm) 74.8x35.4x87.8 (in)
PRODUCT WEIGHT	131.6kg/289.5lbs

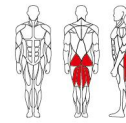

IT9526 GLUTE

PRODUCT DIMENSION (LxWxH)	1503x1245x1506 (mm) 59.2x49x59.3 (in)
PRODUCT WEIGHT	133.6kg/293.9lbs

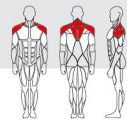

IT9524 LATERAL RAISE

PRODUCT DIMENSION (LxWxH)	1222x1213x1506 (mm) 48.1x47.8x59.3 (in)
PRODUCT WEIGHT	117.5kg/258.5lbs

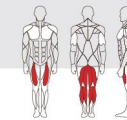

**IT9528
LEG EXTENSION/LEG CURL**

PRODUCT DIMENSION (LxWxH)	1350x1227x1506 (mm) 53.2x48.3x59.3 (in)
PRODUCT WEIGHT	167Kg/368.2lbs

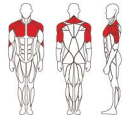

IT9529 MULTI PRESS

PRODUCT DIMENSION (LxWxH)	1827x1437x1667 (mm) 71.9x56.6x65.6 (in)
PRODUCT WEIGHT	166kg/365.9lbs

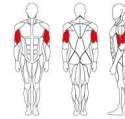

IT9533 BICEP CURL/TRICEP EXTENSION

PRODUCT DIMENSION (LxWxH)	1300x1240x1506(mm) 58.0x55.4x67.2(in)
PRODUCT WEIGHT	132.5kg/291.5lbs

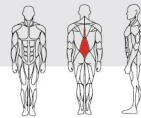

IT9532 BACK EXTENSION

PRODUCT DIMENSION (LxWxH)	1233x1188x1506 (mm) 48.5x56.8x59.3 (in)
PRODUCT WEIGHT	123.7kg/272.1lbs

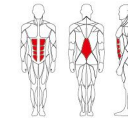

IT9534 ABDOMINAL/BACK EXTENSION

PRODUCT DIMENSION (LxWxH)	1196x1189x1506(mm) 53.4x50.8x61.7(in)
PRODUCT WEIGHT	139.2kg/306.2lbs



IT7001 SMITH

PRODUCT DIMENSION (L×W×H)	2241×1326×2370 (mm) 88.2×52.2×93.3 (in)
PRODUCT WEIGHT	178 kg / 392 lbs
40'	58 Sets
MAX. WEIGHT CAPACITY	200 kg / 440 lbs



IT7002 SEATED PREACHER CURL

PRODUCT DIMENSION (L×W×H)	919×803×882 (mm) 36.2×31.6×34.7 (in)
PRODUCT WEIGHT	41 kg / 90 lbs
40'	260 Sets



IT7005 SEATED CALF RAISE

PRODUCT DIMENSION (L×W×H)	1356×751×831 (mm) 53.4×29.6×32.7 (in)
PRODUCT WEIGHT	50 kg / 110 lbs
40'	297 Sets
MAX. WEIGHT CAPACITY	100 kg / 220 lbs



IT7006 LEG PRESS/HACK SQUAT

PRODUCT DIMENSION (L×W×H)	2253×975×1475 (mm) 88.7×38.4×58.1 (in)
PRODUCT WEIGHT	166.3 kg / 367 lbs
40'	66 Sets
MAX. WEIGHT CAPACITY	200 kg / 440 lbs



IT7003 AB BENCH

PRODUCT DIMENSION (L×W×H)	1745×936×997 (mm) 68.7×36.9×39.3 (in)
PRODUCT WEIGHT	57 kg / 126 lbs
40'	110 Sets



IT7004 STRETCH

PRODUCT DIMENSION (L×W×H)	1274×552×997 (mm) 50.2×21.7×39.3 (in)
PRODUCT WEIGHT	35 kg / 77 lbs
40'	280 Sets



IT7007 MULTI HYPEREXTENSION

PRODUCT DIMENSION (L×W×H)	1312×749×814 (mm) 51.7×29.5×32 (in)
PRODUCT WEIGHT	43.5 kg / 96 lbs
40'	231 Sets



IT7019 INCLINE ROW

PRODUCT DIMENSION (L×W×H)	1965×1009×1262 (mm) 77.4×39.7×49.7 (in)
PRODUCT WEIGHT	77.5 kg / 171 lbs
40'	140 Sets
MAX. WEIGHT CAPACITY	150 kg / 330 lbs



IT7020 45 LEG PRESS

PRODUCT DIMENSION (L×W×H)	2199×1016×1494 (mm) 86.6×40×58.8 (in)
PRODUCT WEIGHT	140.5 kg / 310 lbs
40"	71 Sets
MAX. WEIGHT CAPACITY	200 kg / 440 lbs



IT7010 VERTICAL KNEE RAISE

PRODUCT DIMENSION (L×W×H)	1131×781×1515 (mm) 44.5×30.7×59.6 (in)
PRODUCT WEIGHT	53 kg / 117 lbs
40"	160 Sets



IT7010EOPT CHIN-UP AND DIP

DIMENSION (L×W×H)	2299×930×660 (mm) 90.5×36.6×26 (in)
PRODUCT WEIGHT	30.5kg/67.3lbs



IT7014 FLAT BENCH PRESS

PRODUCT DIMENSION (L×W×H)	1657×1658×1373 (mm) 65.2×65.3×54.1 (in)
PRODUCT WEIGHT	82 kg / 181 lbs
40"	126 Sets



IT7014OPT SPOTTER STAND

PRODUCT DIMENSION (L×W×H)	661×442×262 (mm) 26.0×17.4×10.3 (in)
PRODUCT WEIGHT	25.1 kg/55.2 lbs
40"	680 Sets



IT7015 INCLINE BENCH PRESS

PRODUCT DIMENSION (L×W×H)	1632×1658×1373 (mm) 64.3×65.3×54.1 (in)
PRODUCT WEIGHT	106.5 kg / 235 lbs
40"	112 Sets



IT7016 DECLINE BENCH PRESS

PRODUCT DIMENSION (L×W×H)	2103×1658×1370 (mm) 82.8×65.3×53.9 (in)
PRODUCT WEIGHT	87 kg / 192 lbs
40"	126 Sets



IT7013 MULTI AB BENCH

PRODUCT DIMENSION (L×W×H)	1738×725×899 (mm) 68.4×28.5×35.4 (in)
PRODUCT WEIGHT	42.5 kg / 94 lbs
40'	140 Sets



IT7009 FLAT BENCH

PRODUCT DIMENSION (L×W×H)	1200×748.6×426 (mm) 47.2×29.5×16.8 (in)
PRODUCT WEIGHT	27.5 kg / 61 lbs
40'	220 Sets



IT7011 MULTI-ADJUSTABLE BENCH

PRODUCT DIMENSION (L×W×H)	1212×750×465 (mm) 47.7×29.5×18.3 (in)
PRODUCT WEIGHT	40 kg / 88 lbs
40'	207 Sets



IT7022 UTILITY BENCH

PRODUCT DIMENSION (L×W×H)	1165×603×818 (mm) 45.9×23.7×32.2 (in)
PRODUCT WEIGHT	21.3 kg / 47 lbs
40'	308 Sets



IT7030 ROMAN CHAIR

DIMENSION (L×W×H)	985×726×625 (mm) 38.8×28.6×24.6 (in)
PRODUCT WEIGHT	35kg/77.2lbs





IT7012 DUMBBELL RACK

PRODUCT DIMENSION (L×W×H)	1657×1658×1373 (mm) 65.2×65.3×54.1 (in)
PRODUCT WEIGHT	82 kg / 181 lbs
40'	126 Sets



IT7018 DUMBBELL RACK

PRODUCT DIMENSION (L×W×H)	1580×814×982 (mm) 62.2×32×38.7 (in)
40'	140 Sets



IT7017 WEIGHT PLATE TREE

PRODUCT DIMENSION (L×W×H)	950×610×1220 (mm) 37.4×24×48 (in)
PRODUCT WEIGHT	26 kg / 57 lbs
40'	264 Sets



IT7027 BARBELL RACK

PRODUCT DIMENSION (L×W×H)	919×907×1612 (mm) 36.2×35.7×63.5 (in)
PRODUCT WEIGHT	68 kg / 150 lbs
40'	112 Sets



IT7032 OLYMPIC BAR RACK

DIMENSION (L×W×H)	960×710×1086 (mm) 37.8×28×42.8 (in)
PRODUCT WEIGHT	47 kg/103.7 lbs
MAX. WEIGHT CAPACITY	300 kg/660 lbs



IT7031 SHOULDER BENCH PRESS

DIMENSION (L×W×H)	1349×1126×1651 (mm) 53.1×44.3×65 (in)
PRODUCT WEIGHT	86.5 kg/190.9 lbs
MAX. WEIGHT CAPACITY	300 kg/660 lbs

IT7033 MAX RACK

DIMENSION (L×W×H)	2000×1410×2185 (mm) 78.7×55.5×86 (in)
PRODUCT WEIGHT	199.4 kg/440 lbs
MAX. WEIGHT CAPACITY	200 kg/440 lbs





PL Line >>>

Easy to use, neat appearance, the PL line is a high quality dual/multi functional machines Light commercial/commercial series. This PL line is Impulse dual/multi functional line. The user-friendly design makes working out more simple, efficient, comfortable and satisfying.

Instructive - simple, step-by-step instructions and training tips help users get the most out of their exercise.

Aircraft spec 5mm American LOOS cable with a 2,000 lb breaking strength. End fittings tested to 250,000 cycles using full weight stack.

Easy-to-use, minimal adjustments and pre-stretch features allow for optimal exercise positions.

Glass fiber reinforced nylon pulleys with deep V-groove provides secure cable seating and fluid bearing rotation.

Compact - space efficient design requires minimal floor space.

Shroud is applied to protect the equipment or the possible injury during operation.

Tubing: 2.5 mm to 2.75mm. square tube differ into any types, from 30x60mm to 50x100mm, electro-welded to maximum integrity.

Pad total thickness is 70mm.



Color: metallic silver gray (Other colors are optional based on customer requirements)

STRENGTH
PL



PL9002
LAT PULLDOWN/SEATED ROW

PRODUCT DIMENSION (L×W×H)	1764×1019×2182 (mm) 69.4×40.1×85.9 (in)
PRODUCT WEIGHT	90.5 kg / 200 lbs
40"	136 Sets

PL9010
LEG PRESS/CALF RAISE

PRODUCT DIMENSION (L×W×H)	1938×1148×1520 (mm) 76.3×45.2×59.8 (in)
PRODUCT WEIGHT	111 kg / 245 lbs
40"	88 Sets



PL9016
OUTER/INNER THIGH

PRODUCT DIMENSION (L×W×H)	1609×722×1515 (mm) 63.3×28.4×59.6 (in)
PRODUCT WEIGHT	99 kg / 218 lbs
40"	130 Sets



PL9019
LEG EXTENSION/LEG CURL

PRODUCT DIMENSION (L×W×H)	1465×1245×1520 (mm) 57.7×49×59.8 (in)
PRODUCT WEIGHT	115.5 kg / 255 lbs
40"	75 Sets



STRENGTH
PL

STRENGTH

PL



PL9021 MULTI PRESS

PRODUCT DIMENSION (L×W×H)	1924×1325×1518 (mm) 75.7×52.2×59.8 (in)
PRODUCT WEIGHT	111.5 kg / 246 lbs
40'	120 Sets



PL9022 REAR DELTOID/PECTORAL FLY

PRODUCT DIMENSION (L×W×H)	1362×1219×2061 (mm) 53.6×48.0×81.1 (in)
PRODUCT WEIGHT	107 kg / 236 lbs
40'	124 Sets



PL9023 BICEPS/TRICEPS

PRODUCT DIMENSION (L×W×H)	1207×1164×1513 (mm) 47.5×45.8×59.6 (in)
PRODUCT WEIGHT	106 kg / 234 lbs
40'	115 Sets

PL9024 AB/LOW BACK

PRODUCT DIMENSION (L×W×H)	1044×1094×1520 (mm) 41.1×43.1×59.8 (in)
PRODUCT WEIGHT	99.5 kg / 219 lbs
40'	135 Sets



STRENGTH

PL

IF Line >>>

These simple, clean-lines, selectorized series specially designed for entry level small clubs and institutional applications. It offers a complete functional package, is inexpensive to own and is easy to maintain. It matches up beautifully with the benches and racks of the IF line.

Instructive - simple, step-by-step instructions and training tips help users get the most out of their exercise. Makes exercise easy and enjoyable

Necessary shroud with ABS material are applied to protect the equipment or the possible injury during operation

Tubing: 2.5mm thickness, size in 38x38 mm to 50.8x76.2, electro-welded to maximum integrity

Easy-to-use, minimal adjustments and pre-stretch features allow for optimal exercise positions

Color: metallic silver gray (Other colors are optional based on customer requirements)

Compact - space efficient design requires minimal floor space

Pad total thickness is 70mm

Aircraft spec 5mm cable with a 2,000 lb breaking strength. End fittings tested to 250,000 cycles using full weight stack

Finish: Electrostatic powder-coated and heat cured after adhesiveness enhancement pre-treatment for superior durability

Rubber grip prevent from being slipped



IF8101 CHEST PRESS

PRODUCT DIMENSION (L×W×H)	913×1265×1400 (mm) 35.9×49.8×55.1 (in)
PRODUCT WEIGHT	84 kg / 185 lbs
40'	77 Sets



IF8102 LAT PULLDOWN/LOW ROW

PRODUCT DIMENSION (L×W×H)	1972×913×2177 (mm) 77.6×35.9×85.7 (in)
PRODUCT WEIGHT	96.5 kg / 213 lbs
40'	70 Sets



IF8103 ARM CURL

PRODUCT DIMENSION (L×W×H)	1118×896×1400 (mm) 44.0×35.3×55.1 (in)
PRODUCT WEIGHT	87.5 kg / 193 lbs
40'	84 Sets



IF8105 LEG EXTENSION

PRODUCT DIMENSION (L×W×H)	1192×1167×1400 (mm) 46.9×45.9×55.1 (in)
PRODUCT WEIGHT	100.5 kg / 222 lbs
40'	69 Sets



IF8106 SEATED LEG CURL

PRODUCT DIMENSION (L×W×H)	1436×1170×1400 (mm) 56.5×46.1×55.1 (in)
PRODUCT WEIGHT	103.5 kg / 228 lbs
40'	69 Sets



IF8109 TOTAL HIP

PRODUCT DIMENSION (L×W×H)	1208×1005×1480 (mm) 47.6×39.6×58.3 (in)
PRODUCT WEIGHT	88.5 kg / 195 lbs
40'	100 Sets



IF8116 INNER/OUTER THIGH

PRODUCT DIMENSION (L×W×H)	1643×697×1506 (mm) 64.7×27.4×59.3 (in)
PRODUCT WEIGHT	96.5 kg / 213 lbs
40'	85 Sets



IF8120 WEIGHT ASSISTED CHIN/DIP COMBO

PRODUCT DIMENSION (L×W×H)	1466×1225×2139 (mm) 57.7×48.2×84.2 (in)
PRODUCT WEIGHT	121.5 kg / 268 lbs
40'	90 Sets



IF8110 LEG PRESS/CALF RAISE

PRODUCT DIMENSION (L×W×H)	1541×1220×1701 (mm) 60.7×48×67 (in)
PRODUCT WEIGHT	147.5 kg / 325 lbs
40'	54 Sets



IF8112 SHOULDER PRESS

PRODUCT DIMENSION (L×W×H)	1392×1191×1400 (mm) 54.8×46.9×55.1 (in)
PRODUCT WEIGHT	87 kg / 192 lbs
40'	80 Sets



IF8121 MULTI PRESS

PRODUCT DIMENSION (L×W×H)	1818×1337×1400 (mm) 71.6×52.6×55.1 (in)
PRODUCT WEIGHT	110.5 kg / 244 lbs
40'	72 Sets



IF8122 PEC FLY/REAR DELT

PRODUCT DIMENSION (L×W×H)	1310×1450×1810 (mm) 51.6×57.1×71.3 (in)
PRODUCT WEIGHT	100.5 kg / 222 lbs
40'	81 Sets



IF8123 BICEP/TRICEP

PRODUCT DIMENSION (L×W×H)	1260×849×2115 (mm) 49.6×33.4×83.3 (in)
PRODUCT WEIGHT	76 kg / 168 lbs
40'	91 Sets



IF8124 AB/BACK

PRODUCT DIMENSION (L×W×H)	1217×1057×1400 (mm) 47.9×41.6×55.1 (in)
PRODUCT WEIGHT	79.5 kg / 175 lbs
40'	94 Sets



IF8125 ADJUSTABLE HI / LO PULLEY

PRODUCT DIMENSION (L×W×H)	1304×979×2494 (mm) 51.3×38.5×98.2 (in)
PRODUCT WEIGHT	96 kg / 212 lbs
40'	108 Sets



IF8127 4 STACK MULTI-STATION

PRODUCT DIMENSION (L×W×H)	3688×1988×2501 (mm) 145.2×78.3×98.5 (in)
PRODUCT WEIGHT	258.6 kg / 570 lbs
40'	48 Sets



IF8127OPT CABLE CROSSOVER-TRADITIONAL

PRODUCT DIMENSION (L×W×H)	2538×498×200 (mm) 99.9×19.6×7.9 (in)
PRODUCT WEIGHT	21.5 kg / 47 lbs
40'	526 Sets



CABLE CROSSOVER

IF8125+IF8125+IF8127OPT

PRODUCT DIMENSION (L×W×H)	3880x1295x2494(mm) 153x51x98(in)
------------------------------	-------------------------------------

5 STACK MULTI-STATION

IF8125+IF8127+IF8127OPT

PRODUCT DIMENSION (L×W×H)	5006x3686x2498(mm) 197x145x98(in)
------------------------------	--------------------------------------



8 STACK MULTI-STATION

IF8127+IF8127+IF8127OPT

PRODUCT DIMENSION (L×W×H)	6071x4321x2498(mm) 239x170x98(in)
------------------------------	--------------------------------------



IFHC
HALF CAGE

PRODUCT DIMENSION (L×W×H)	1690×1725×2090 (mm) 66.5×67.9×82.3 (in)
PRODUCT WEIGHT	100 kg / 221 lbs
40'	150 Sets



IFHCL
HALF CAGE LAT ATTACHMENT

PRODUCT DIMENSION (L×W×H)	1800×400×2100 (mm) 70.9×15.7×82.7 (in)
PRODUCT WEIGHT	41 kg / 90 lbs
40'	234 Sets



IFHCP
HALF CAGE PEC FLY ATTACHMENT

PRODUCT DIMENSION (L×W×H)	953×356×1538 (mm) 37.5×14×60.6 (in)
PRODUCT WEIGHT	24.3 kg / 54 lbs
40'	508 Sets



IFHCS
HALF CAGE SMITH ATTACHMENT

PRODUCT DIMENSION (L×W×H)	1946×300×1727 (mm) 76.6×11.8×68 (in)
PRODUCT WEIGHT	33 kg / 73 lbs
40'	425 Sets
MAX. WEIGHT CAPACITY	200 kg / 440 lbs

IFLATM
LAT MACHINE

PRODUCT DIMENSION (L×W×H)	1452×1224×2129 (mm) 57.2×48.2×83.8 (in)
PRODUCT WEIGHT	55.5 kg / 122 lbs
40'	302 Sets



IFPC
POWER CAGE

PRODUCT DIMENSION (L×W×H)	1231×1231×2110 (mm) 48.5×48.5×83.1 (in)
PRODUCT WEIGHT	114 kg / 251 lbs
40'	90 Sets

IFPCL
POWER CAGE LAT ATTACHMENT

PRODUCT DIMENSION (L×W×H)	2061×1213×958 (mm) 81.1×47.8×37.7 (in)
PRODUCT WEIGHT	31.8 kg / 70 lbs
40'	420 Sets





IF45
45-DEGREE HYPEREXTENSION

PRODUCT DIMENSION (L×W×H)	1212×743×772 (mm) 47.7×29.3×30.4 (in)
PRODUCT WEIGHT	23.5 kg / 52 lbs
40'	340 Sets



IFAH
ADJUSTABLE HYPEREXTENSION BENCH

PRODUCT DIMENSION (L×W×H)	1260×743×917 (mm) 49.6×29.3×36.1 (in)
PRODUCT WEIGHT	36 kg / 79 lbs
40'	360 Sets



IFAAB
ADJUSTABLE ABDOMINAL BENCH

PRODUCT DIMENSION (L×W×H)	1683×568×1148 (mm) 66.3×22.4×45.2 (in)
PRODUCT WEIGHT	24 kg / 53 lbs
40'	450 Sets



IFAC
ABDOMINAL CRUNCH

PRODUCT DIMENSION (L×W×H)	1103×476×578 (mm) 43.4×18.7×22.8 (in)
PRODUCT WEIGHT	17 kg / 37 lbs
40'	697 Sets



IFRC
ROMAN CHAIR

PRODUCT DIMENSION (L×W×H)	1361×743×1091 (mm) 53.6×29.3×43 (in)
PRODUCT WEIGHT	30.5 kg / 67 lbs
40'	504 Sets



IFSPC
SEATED PREACHER CURL

PRODUCT DIMENSION (L×W×H)	1021×712×824 (mm) 40.2×28×32.4 (in)
PRODUCT WEIGHT	24.7 kg / 54 lbs
40'	420 Sets



IFFB
FLAT BENCH

PRODUCT DIMENSION (L×W×H)	1305×525×493 (mm) 51.4×20.7×19.4 (in)
PRODUCT WEIGHT	19.5 kg / 43 lbs
40'	532 Sets



IFUB
UTILITY BENCH

PRODUCT DIMENSION (L×W×H)	862×596×874 (mm) 33.9×23.5×34.4 (in)
PRODUCT WEIGHT	12.7 kg / 28 lbs
40'	375 Sets



IFSTF STRETCH

PRODUCT DIMENSION (L×W×H)	1866×1730×2150 (mm) 73.5×68.1×84.6 (in)
PRODUCT WEIGHT	90 kg / 198 lbs
40'	112 Sets



IFPT POWER TOWER

PRODUCT DIMENSION (L×W×H)	1320×610×2105 (mm) 52×24×82.9 (in)
PRODUCT WEIGHT	76.5 kg / 169 lbs
40'	245 Sets



IFOB OLYMPIC BENCH PRESS

PRODUCT DIMENSION (L×W×H)	1438×1264×1468 (mm) 56.6×49.8×57.8 (in)
PRODUCT WEIGHT	62.5 kg / 138 lbs
40'	252 Sets

IFARMA ARM CURL ATTACHMENT

PRODUCT DIMENSION (L×W×H)	584×434×761 (mm) 23×17.1×30 (in)
PRODUCT WEIGHT	6.6 kg / 15 lbs
40'	840 Sets



IFFI FLAT/INCLINE BENCH

PRODUCT DIMENSION (L×W×H)	1603×654×498 (mm) 63.1×25.7×19.6 (in)
PRODUCT WEIGHT	30 kg / 66 lbs
40'	396 Sets



IFFID MULTI-PURPOSE BENCH

PRODUCT DIMENSION (L×W×H)	1581×654×515 (mm) 62.2×25.7×20.3 (in)
PRODUCT WEIGHT	33 kg / 73 lbs
40'	417 Sets



IFLEGA LEG EXTENSION/CURL ATTACHMENT

PRODUCT DIMENSION (L×W×H)	485×426×470 (mm) 19.1×16.8×18.5 (in)
PRODUCT WEIGHT	7.3 kg / 16 lbs
40'	1728 Sets

STRENGTH

IF



**IFLPHS
LEG PRESS/HACK SQUAT MACHINE**

PRODUCT DIMENSION (L×W×H)	2285×820×1295 (mm) 90×32.3×51 (in)
PRODUCT WEIGHT	162.5 kg / 358 lbs
40'	108 Sets
MAX. WEIGHT CAPACITY	200 kg / 440 lbs

**IFSS
SQUAT STAND**

PRODUCT DIMENSION (L×W×H)	1226×1575×1735 (mm) 48.3×62×68.3 (in)
PRODUCT WEIGHT	56.5 kg / 125 lbs
40'	320 Sets



**IFOFB
FLAT BENCH PRESS**

PRODUCT DIMENSION (L×W×H)	1525×1310×1265 (mm) 60×51.6×49.8 (in)
PRODUCT WEIGHT	60.5 kg / 133 lbs
40'	154 Sets



**IFOIB
INCLINE BENCH PRESS**

PRODUCT DIMENSION (L×W×H)	1560×1310×1192 (mm) 61.4×51.6×46.9 (in)
PRODUCT WEIGHT	68.5 kg / 151 lbs
40'	147 Sets



**IFODB
DECLINE BENCH PRESS**

PRODUCT DIMENSION (L×W×H)	1900×1310×1156 (mm) 74.8×51.6×45.5 (in)
PRODUCT WEIGHT	70 kg / 154 lbs
40'	154 Sets



STRENGTH

IF



**IFABM
AB/BACK MACHINE**

PRODUCT DIMENSION (L×W×H)	1520×1005×1060 (mm) 59.8×39.6×41.7 (in)
PRODUCT WEIGHT	38.5 kg / 85 lbs
40'	119 Sets



**IFCR
CALF RAISE**

PRODUCT DIMENSION (L×W×H)	1100×560×850 (mm) 43.3×22×33.5 (in)
PRODUCT WEIGHT	35.5 kg / 78 lbs
40'	520 Sets
MAX. WEIGHT CAPACITY	100 kg / 220 lbs

**IFLEGM
LEG EXTENSION/CURL MACHINE**

PRODUCT DIMENSION (L×W×H)	1215×1045×1047 (mm) 47.8×41.1×41.2 (in)
PRODUCT WEIGHT	51 kg / 112 lbs
40'	192 Sets



**IFBR
BARBELL RACK**

PRODUCT DIMENSION (L×W×H)	792×844×1380 (mm) 31.2×33.2×54.3 (in)
PRODUCT WEIGHT	43.7 kg / 96 lbs
40'	195 Sets



**IFPTO
PLATE TREE-OLYMPIC**

PRODUCT DIMENSION (L×W×H)	843×632×1108 (mm) 33.2×24.9×43.6 (in)
PRODUCT WEIGHT	19.5 kg / 43 lbs
40'	890 Sets



**IFDB3
DUMBBELL RACK-3'**

PRODUCT DIMENSION (L×W×H)	1079×473×677 (mm) 42.5×18.6×26.7 (in)
PRODUCT WEIGHT	29 kg / 64 lbs
40'	600 Sets



**IFDB4
DUMBBELL RACK-4'**

PRODUCT DIMENSION (L×W×H)	1372×473×869 (mm) 54×18.6×34.2 (in)
PRODUCT WEIGHT	35.3 kg / 78 lbs
40'	430 Sets



**IFDB4A
DUMBBELL RACK-4' ATTACHMENT**

PRODUCT DIMENSION (L×W×H)	1242×244×74 (mm) 48.9×9.6×2.9 (in)
PRODUCT WEIGHT	12 kg / 26 lbs
40'	1400 Sets

**IF2060
2060 HOME GYM**

PRODUCT DIMENSION (L×W×H)	2298×1956×2120 (mm) 90.5×77×83.5 (in)
PRODUCT WEIGHT	442.8 kg / 976 lbs
40'	40 Sets
WEIGHT STACK	2×91 kg / 200 lbs



**IFLP3
HOME GYM ATTACHMENT**

PRODUCT DIMENSION (L×W×H)	1673×1039×967 (mm) 65.9×40.9×38.1 (in)
PRODUCT WEIGHT	65 kg / 143 lbs
40'	220 Sets



IF1860+IFLP3



IF2060+IFLP3



**IF1560
1560 HOME GYM**

PRODUCT DIMENSION (L×W×H)	1905×1240×2121 (mm) 75×48.8×83.5 (in)
PRODUCT WEIGHT	223 kg / 492 lbs
40'	68 Sets
WEIGHT STACK	91 kg / 200 lbs



**IF1860
1860 HOME GYM**

PRODUCT DIMENSION (L×W×H)	1799×1207×2114 (mm) 70.8×47.5×83.2 (in)
PRODUCT WEIGHT	253.7 kg / 559 lbs
40'	60 Sets
WEIGHT STACK	91 kg / 200 lbs



IFFT FUNCTIONAL TRAINER

PRODUCT DIMENSION (L×W×H)	900×1800×2130 (mm) 35.4×70.9×83.9 (in)
PRODUCT WEIGHT	336 kg / 741 lbs
40'	56 Sets
WEIGHT STACK	2×91 kg / 200 lbs

IFFTOPT MULTI-SELECT STABILIZER

PRODUCT DIMENSION (L×W×H)	1075×260×1120 (mm) 42.3×10.2×44 (in)
PRODUCT WEIGHT	17.3 kg / 38 lbs
	IFFT+IFFTOPT



IFCC CABLE CROSSOVER

PRODUCT DIMENSION (L×W×H)	3660×1040×2120 (mm) 144.1×40.9×83.5 (in)
PRODUCT WEIGHT	291 kg / 642 lbs
40'	68 Sets
WEIGHT STACK	2×68 kg / 150 lbs



HG5 CABLE MOTION GYM

PRODUCT DIMENSION (L×W×H)	1451×1339×2132 (mm) 57.1×52.7×83.9 (in)
PRODUCT WEIGHT	202 kg / 445.4 lbs
40'	82 Sets
WEIGHT STACK	73 kg / 160 lbs



IFFI5 BENCH

PRODUCT DIMENSION (L×W×H)	1380×490×441 (mm) 54.3×19.3×17.3 (in)
PRODUCT WEIGHT	25.7kgs/56.7lbs
MAX WEIGHT CAPACITY	200kg/441lbs



Jungle >>>



Multiple accessory racks enable user to put stuff and easy of access.

Shroud is made of translucent injection molding ABS which make the machine safer and good-looking.

Use dual-pulley for high rowing and low rowing. Increase diversity of motion.

Switch from high rowing to low rowing which accomodates different sizes of training field yet saving space either.



Larger distance between left and right upright accomodates a variety of users needs. No interference for users during exercise. (distance between sliding rail is 2680mm)

Multi-handle grips accomodate a variety of user training demands

Thanks to 1785mm sliderail, the hand grips could be adjusted from 1 to 36 degree. It helps to train almost total body muscle groups.

Use stainless steel roller tubing that prevent machine from wearing and corrosion.

Larger size of groundtubing strengthen stablization of machine

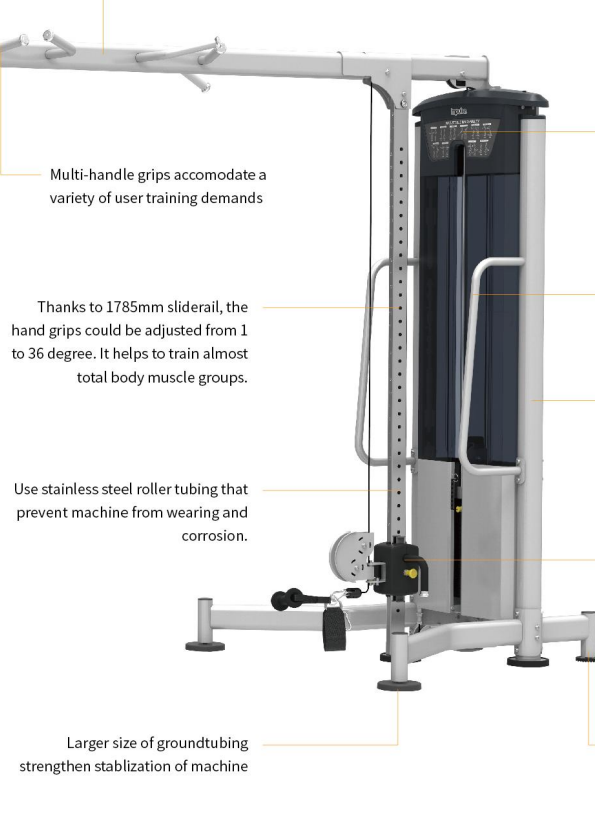

Perfect training placard enable detailed and professional guide to workout

Assistance handle bar: Easy hand grips help user keeping balance in exercise and enable more strength training.

Use 3.0mm thickness tube and spray powder coated. It has enhanced corrosion resistance and better appearance.

A roller type of pulley enables glide smooth and easy to adjust

The height of groundpads are adjustable which guarantees the stablization of machine.

* TRANSPARENT SHROUD IS OPTIONAL.



IT9525 ADJUSTABLE HI/LO PULLEY

PRODUCT DIMENSION (LxWxH)	1450x1245x2350(mm) 57.1x49.0x92.5(in)
PRODUCT WEIGHT	93.9Kg/206.58lbs (TBD)

* TRANSPARENT SHROUD IS OPTIONAL.



IT9530 DUAL ADJUSTABLE PULLEY

PRODUCT DIMENSION (LxWxH)	1620x1370x2270(mm) 63.8x54.0x59.4(in)
PRODUCT WEIGHT	165kg/363lbs (TBD)



IT9527 4 STACK MULTI-STATION

PRODUCT DIMENSION (LxWxH)	3489x1968x2382(mm) 137.4x77.5x93.8(in)
PRODUCT WEIGHT	295Kg/649lbs (TBD)

* TRANSPARENT SHROUD IS OPTIONAL.

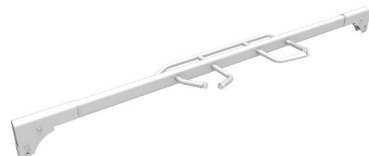

IT9527OPT CABLE CROSSOVER-TRADITIONAL

PRODUCT DIMENSION (LxWxH)	2824x222x483(mm) 111.2x8.74x19.0(in)
PRODUCT WEIGHT	29Kg/63.8lbs (TBD)



IT9525+IT9525+IT9527OPT

PRODUCT DIMENSION (LxWxH)	4196x1436x2360(mm) 165.2x56.5x92.9(in)
---------------------------	---

IT9525+IT9527+IT9527OPT

PRODUCT DIMENSION (LxWxH)	5089x3489x2380(mm) 200.4x137.4x93.7(in)
---------------------------	--



IT9527+IT9527+IT9527OPT

PRODUCT DIMENSION (LxWxH)	5982x3489x2380(mm) 235.5x137.4x93.7(in)
---------------------------	--

* TRANSPARENT SHROUD IS OPTIONAL.

ES3000 3 STACK MULTI-STATION

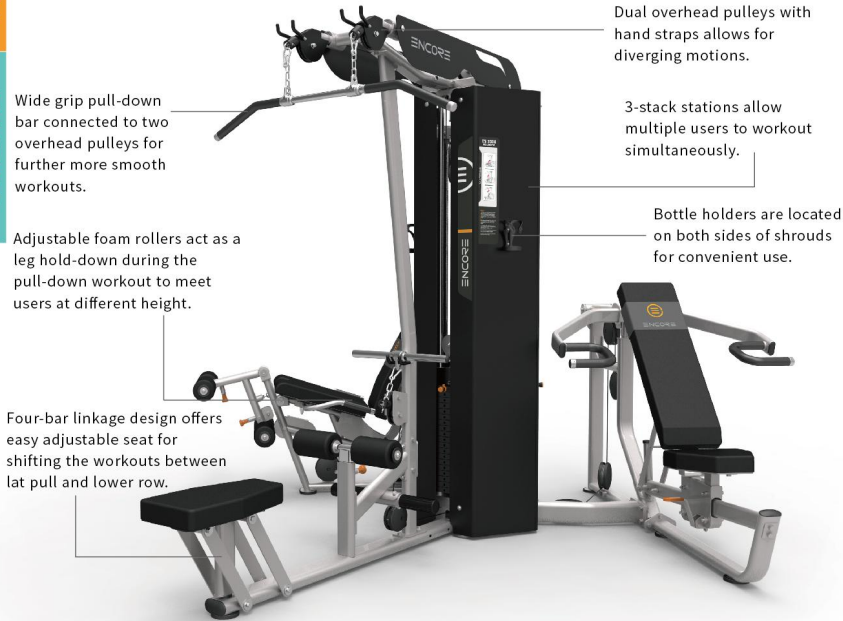

Product Dimension (L×W×H)	2705x2455x2148(mm) 106.50x96.65x84.57(in)
Product Weight	573kg
Stacks Weight	91kgx3 (200lbsx3)
OPT Weight	26.5kg



ES3000 OPT HI-LO PULLEY ATTACHMENT

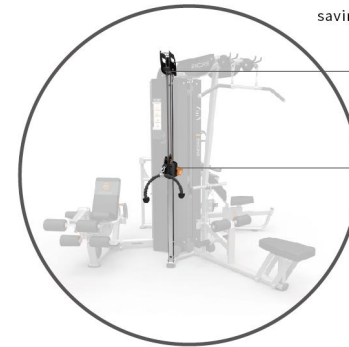

Quick installation, shares the stack with lat pull for saving space and cost.

31 vertical pulley positions for a large variety of different exercises.



Excellent structural design, easy & quick adjustment offers dynamic workout like chest press, incline press and should press which meet various muscle groups training.



Adjustable handle is conveniently located for easy access.

Excellent structural design, easy & quick adjustment seat is for prone leg curls or leg extension exercises which satisfy various muscle groups.

ES9030 DUAL ADJUSTABLE PULLEY
ES7011 BENCH



Chin-up/pull-up bar with ergonomic bends for regular grip, wide grip and reverse grip exercises.

Conveniently located iPad holder allows user to watch online training videos during the workouts, over-sized bottle holder is within reach.

31 vertical pulley positions for a large variety of different exercises.

With accessories as lat strap, long bar retractable strap, leg ext/curl strap and tricep rope, DAP offers users dynamic and various workouts.

Multi-position bench offers 5 upright/incline positions for back pad and 3 position for seat, which satisfies various workout experience.

The over-sized feet would stabilize the users during certain workouts like tricep extension.



Fold away bench for easy storage and space saving



ES9030(Long Shroud)

Product Dimension (L×W×H)	1734x1123x2150(mm) 68.27x44.21x84.65(in)
Product Weight	149.5kg/328.9lbs
Stacks Weight	77kgx2 (170lbsx2)



ES9030(Short Shroud)

Product Dimension (L×W×H)	1734x1123x2150(mm) 68.27x44.21x84.65(in)
Product Weight	121.5kg/267.3lbs
Stacks Weight	77kgx2 (170lbsx2)



ES7011

Product Dimension (L×W×H)	1440x525x489(mm) 56.69x20.67x19.25(in)
Product Weight	34.5kg

Chest

- Incline Press
- Chest Press
- Decline Press
- Pec Fly
- Incline Press
- Chest Press

Arms

- Bicep Curl
- Tricep Press Down

Core

- Knéeing Crunch
- Dead Lift
- Core Rotation
- Core Rotation Incline
- Core Rotation Decline

Back

- High Row
- Mid Row
- Low Row
- Rear Deltoid
- Pull Up

Lower Body

- Squat
- Lunge
- Lunge/Decelerating
- Hip Adduction
- Hip Abduction
- Hip Flexion
- Hip Extension
- Kick Back
- Leg Extension
- Leg Curl

Shoulders

- Searched Shoulder Press
- Lateral Raise
- Internal Rotation
- External Rotation
- Upright Row
- Shoulder Press



SL Line >>>

Easy to use, neat appearance, the SL line is a high quality commercial plate loaded series. The user-friendly design makes working out more simple, efficient, comfortable and satisfying.

Tubing: thickness range from 2.5 mm to 3mm, 50mmx100mm tubing, electro-welded to maximum integrity.

Color: black and red (Other colors are optional based on customer requirements)

Finish: Electrostatic powder-coated and heat cured after adhesiveness enhancement pre-treatment for superior durability



Compact - space efficient design requires minimal floor space.

Pad total thickness is 70mm.

Easy-to-use, flexible adjustments allow for optimal exercise positions.





SL7001 CHEST PRESS

PRODUCT DIMENSION (L×W×H)	1937×1370×1717 (mm) 76.3×53.9×67.6 (in)
PRODUCT WEIGHT	163 kg / 359 lbs
40'	70 Sets
MAX. WEIGHT CAPACITY	300 kg / 660 lbs



SL7002 PULLDOWN

PRODUCT DIMENSION (L×W×H)	1482×1489×1967 (mm) 58.3×58.6×77.4 (in)
PRODUCT WEIGHT	164 kg / 362 lbs
40'	81 Sets
MAX. WEIGHT CAPACITY	300 kg / 660 lbs



SL7004 LOW ROW

PRODUCT DIMENSION (L×W×H)	1761×1457×1652 (mm) 69.3×57.4×65 (in)
PRODUCT WEIGHT	167.5 kg / 369 lbs
40'	69 Sets
MAX. WEIGHT CAPACITY	300 kg / 660 lbs



SL7005 INCLINE CHEST PRESS

PRODUCT DIMENSION (L×W×H)	1900×1523×1779 (mm) 74.8×60×70 (in)
PRODUCT WEIGHT	183.5 kg / 405 lbs
40'	72 Sets
MAX. WEIGHT CAPACITY	300 kg / 660 lbs



SL7003 SHOULDER PRESS

PRODUCT DIMENSION (L×W×H)	1558×1818×1487 (mm) 61.3×71.6×58.5 (in)
PRODUCT WEIGHT	171 kg / 377 lbs
40'	89 Sets
MAX. WEIGHT CAPACITY	300 kg / 660 lbs



SL7006 LEG PRESS

PRODUCT DIMENSION (L×W×H)	2226×1421×1419 (mm) 87.6×55.9×55.9 (in)
PRODUCT WEIGHT	192.5 kg / 424 lbs
40'	65 Sets
MAX. WEIGHT CAPACITY	400 kg / 880 lbs



STRENGTH

SL

SL7007 ROW

PRODUCT DIMENSION (L×W×H)	1815×1500×1334 (mm) 71.5×59.1×52.5 (in)
PRODUCT WEIGHT	157 kg / 346 lbs
40"	87 Sets
MAX. WEIGHT CAPACITY	300 kg / 660 lbs



SL7008 REAR KICK

PRODUCT DIMENSION (L×W×H)	1680×1229×1636 (mm) 66.1×48.4×64.4 (in)
PRODUCT WEIGHT	142 kg / 313 lbs
40"	82 Sets
MAX. WEIGHT CAPACITY	150 kg / 330 lbs

SL7020 45 LEG PRESS

PRODUCT DIMENSION (L×W×H)	2499×1879×1544 (mm) 98.4×74×60.8 (in)
40"	58 Sets
MAX. WEIGHT CAPACITY	450 kg / 990 lbs



SL7021 HACK SQUAT

PRODUCT DIMENSION (L×W×H)	2205×1880×1285 (mm) 86.8×74×50.6 (in)
MAX. WEIGHT CAPACITY	400 kg / 880 lbs

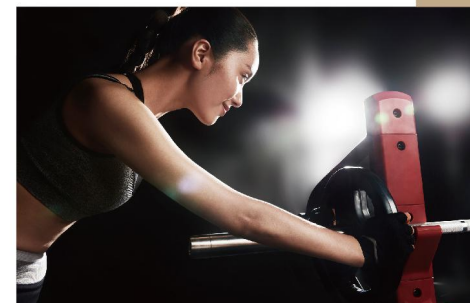

STRENGTH

SL



SL7023 BICEP CURL

PRODUCT DIMENSION (L×W×H)	1403×1045×1200 (mm) 55.2×41.1×47.2 (in)
	96 Sets
MAX. WEIGHT CAPACITY	120 kg / 264 lbs



SL7024 TRICEP DIP

PRODUCT DIMENSION (L×W×H)	1733×1580×1202 (mm) 68.2×62.2×47.3 (in)
MAX. WEIGHT CAPACITY	300 kg / 660 lbs



SL7026 LEG CURL

PRODUCT DIMENSION (L×W×H)	1403×1045×1200 (mm) 55.2×41.1×47.2 (in)
MAX. WEIGHT CAPACITY	120 kg / 264 lbs



SL7034 SQUAT

PRODUCT DIMENSION (L×W×H)	2260×1260×1800 (mm) 88.9×49.6×70.9 (in)
PRODUCT WEIGHT	300 kg/660 lbs
MAX. WEIGHT CAPACITY	400 kg/880 lbs



SL7025 LEG EXTENSION

PRODUCT DIMENSION (L×W×H)	1270×1690×1005 (mm) 50×66.5×39.6 (in)
MAX. WEIGHT CAPACITY	300 kg / 660 lbs

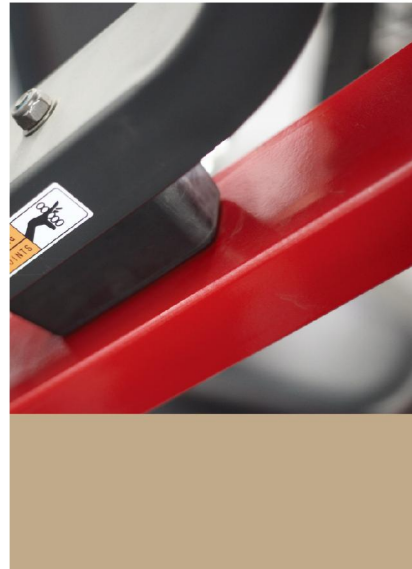

SL7036 ABDOMINAL

PRODUCT DIMENSION (L×W×H)	1623×1267×1642 (mm) 63.9×49.9×64.6 (in)
PRODUCT WEIGHT	120 kg/264 lbs(TBD)
MAX. WEIGHT CAPACITY	120 kg/264 lbs



SL7032 STANDING CALF RAISE

PRODUCT DIMENSION (L×W×H)	1615×1375×1730(mm) 63.6×54.1×68.1 (in)
PRODUCT WEIGHT	175 kg/385 lbs(TBD)
MAX. WEIGHT CAPACITY	300 kg/660 lbs

STRENGTH
SL



SL7009 POWER RACK

PRODUCT DIMENSION (L×W×H)	2031×1499×2278 (mm) 80×59×89.7 (in)
PRODUCT WEIGHT	200 kg / 441 lbs
40'	82 Sets



**SL7009OPT
WEIGHT PLATE RACK OPTION**

PRODUCT DIMENSION (L×W×H)	1674×717×2199 (mm) 65.9×28.2×86.6 (in)
PRODUCT WEIGHT	63.5 kg / 140 lbs
40'	144 Sets

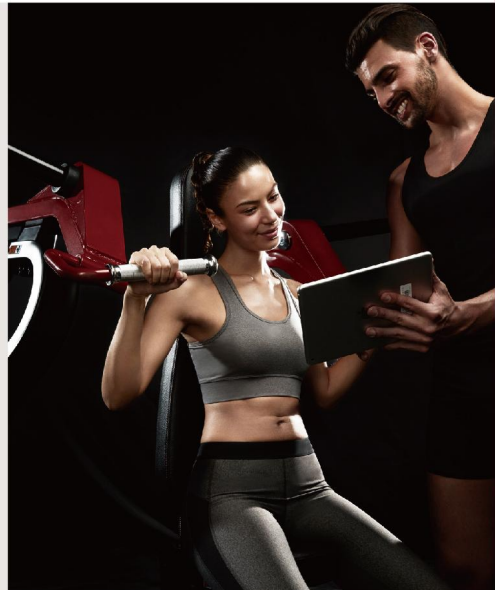

SL7014 HALF POWER RACK

PRODUCT DIMENSION (L×W×H)	1390×1747×2442 (mm) 54.7×68.8×96.1 (in)
PRODUCT WEIGHT	153 kg / 337 lbs
40'	108 Sets

SL7015 FULL POWER RACK

PRODUCT DIMENSION (L×W×H)	1966×1747×2442 (mm) 77.4×68.8×96.1 (in)
PRODUCT WEIGHT	216 kg / 476 lbs
40'	83 Sets



STRENGTH
SL

STRENGTH

SL



SL7028 FLAT BENCH PRESS

PRODUCT DIMENSION (L×W×H)	1910x1738x1315 (mm) 75.2x68.4x51.8 (in)
PRODUCT WEIGHT	112 kg/246 lbs
MAX. WEIGHT CAPACITY	300 kg/660 lbs



SL7029 INCLINE BENCH PRESS

PRODUCT DIMENSION (L×W×H)	2059x1738x1496 (mm) 81.1x68.4x58.9 (in)
PRODUCT WEIGHT	113 kg/249 lbs
MAX. WEIGHT CAPACITY	300 kg/660 lbs



SL7011 FID BENCH

PRODUCT DIMENSION (L×W×H)	1350×670×1350 (mm) 53.1×26.4×53.1 (in)
PRODUCT WEIGHT	44 kg / 97 lbs
40"	252 Sets



SL7012 FI BENCH

PRODUCT DIMENSION (L×W×H)	1550×670×1350 (mm) 61×26.4×53.1 (in)
PRODUCT WEIGHT	47 kg / 104 lbs
40"	252 Sets

STRENGTH

SL



SL7030 DECLINE BENCH PRESS

PRODUCT DIMENSION (L×W×H)	2188x1738x1315 (mm) 86.1x68.4x51.8 (in)
PRODUCT WEIGHT	104 kg/229 lbs
MAX. WEIGHT CAPACITY	300 kg/660 lbs



SL7031 SHOULDER BENCH PRESS

PRODUCT DIMENSION (L×W×H)	1719x1261x1920 (mm) 67.7x49.6x75.6 (in)
PRODUCT WEIGHT	150 kg/330 lbs
MAX. WEIGHT CAPACITY	400 kg/880 lbs



SL7022 UTILITY BENCH

PRODUCT DIMENSION (L×W×H)	1191×630×822 (mm) 46.9×24.8×32.4 (in)
PRODUCT WEIGHT	26.8 kg / 59 lbs
40"	253 Sets



SL7035 FLAT BENCH

PRODUCT DIMENSION (L×W×H)	1281x630x425 (mm) 50.4x24.8x16.7 (in)
PRODUCT WEIGHT	25.5 kg/56 lbs
MAX. WEIGHT CAPACITY	300 kg/660 lbs

STRENGTH

SL



SL7013 GLUTE HAM BENCH

PRODUCT DIMENSION (L×W×H)	1562×914×1477 (mm) 61.5×36×58.1 (in)
PRODUCT WEIGHT	70 kg / 154 lbs
40°	105 Sets



SL7017 SEATED CALF RAISE

PRODUCT DIMENSION (L×W×H)	1475×765×845 (mm) 58×30.1×33.3 (in)
PRODUCT WEIGHT	56 kg / 123 lbs
40°	174 Sets
MAX. WEIGHT CAPACITY	150 kg / 330 lbs



SL7010 PLATE RACK

PRODUCT DIMENSION (L×W×H)	891×628×1228 (mm) 35.1×24.7×48.3 (in)
PRODUCT WEIGHT	44 kg / 97 lbs
40°	242 Sets



SL7027 BARBELL RACK

PRODUCT DIMENSION (L×W×H)	950×910×1612 (mm) 37.4×35.8×63.5 (in)
PRODUCT WEIGHT	73 kg / 161 lbs
40°	112 Sets

STRENGTH

SL



SL7019 INCLINE ROW

PRODUCT DIMENSION (L×W×H)	1960×1020×1253 (mm) 77.2×40.2×49.3 (in)
PRODUCT WEIGHT	89 kg / 196 lbs
40°	97 Sets
MAX. WEIGHT CAPACITY	150 kg / 330 lbs



SL7016 DUMBBELL RACK

PRODUCT DIMENSION (L×W×H)	2260×760×740 (mm) 89.0×29.9×29.1 (in)
PRODUCT WEIGHT	76 kg/167.2 lbs
40°	240 Sets
MAX. WEIGHT CAPACITY	700 kg/ 1540 lbs



SL7018 ARM CURL

PRODUCT DIMENSION (L×W×H)	1140×860×1020 (mm) 44.9×33.9×40.2 (in)
PRODUCT WEIGHT	65kgs/143lbs
MAX.WEIGHT CAPACITY	300kgs/661.4lbs





I-ZONE

Customized Group Functional Training

Impulse Zone offers modularized stations, and each station is interchangeable, which offers full customizability to best suit individual and group fitness needs to emphasize every aspect of functional strength, flexibility and endurance; besides it is also the wonderful choice for clubs looking for cost and space saving while maximizing training options.



Shape	Package	Product Dimension	Optional Accessory Package
IZ-S	IZ7001 Stretching Station IZ7003 Rebounder Station IZ7011 S-joint	3250×1120×2364(mm) 128×44.1×93.1(in)	IZ7009 Step Attachment IZ7010 DIP Attachment IZ7012 Pivot Kettlebell, Battle Rope, TRX, Medicine ball, Bar, Plate etc.
IZ-I	IZ7001 Stretching Station IZ7002 Boxing Station IZ7008 Stair-1	4794×1654×2446(mm) 188.7×65.1×96.3(in)	IZ7009 Step Attachment IZ7010 DIP Attachment IZ7012 Pivot Kettlebell, Punching Bag, Battle Rope, TRX, Medicine ball, Bar, Plate etc.
IZ-L	IZ7001 Stretching Station IZ7002 Boxing Station IZ7003 Rebounder Station IZ7008 Stair-1 IZ7011 S-joint	4794×3250×2446(mm) 188.7×128×96.3(in)	IZ7009 Step Attachment IZ7010 DIP Attachment IZ7012 Pivot Kettlebell, Punching Bag, Battle Rope, TRX, Medicine ball, Bar, Plate etc.
IZ-T	IZ7003 Rebounder Station IZ7004 Power Rack Station IZ7005 DAP Station IZ7006 Connector IZ7007 Stair-2	4694×3139×2446(mm) 184.8×123.6×96.3(in)	IZ7009 Step Attachment IZ7010 DIP Attachment IZ7012 Pivot Kettlebell, Battle Rope, TRX, Medicine ball, Bar, Plate etc.
IZ-O	IZ7001 Stretching Station IZ7002 Boxing Station IZ7003 Rebounder Station IZ7005 DAP Station IZ7014 Stair-3	3637×3630×2446(mm) 141.3×136.7×96.3(in)	IZ7009 Step Attachment IZ7010 DIP Attachment IZ7012 Pivot Kettlebell, Punching Bag, Battle Rope, TRX, Medicine ball, Bar, Plate etc.
IZ-H	IZ7001 Stretching Station IZ7002 Boxing Station IZ7003 Rebounder Station IZ7005 DAP Station IZ7015 Stair-4	4137×2880×2449(mm) 162.9×113.4×96.4(in)	IZ7009 Step Attachment IZ7010 DIP Attachment IZ7012 Pivot Kettlebell, Punching Bag, Battle Rope, TRX, Medicine ball, Bar, Plate etc.
IZ-X	IZ7002 Boxing Station IZ7003 Rebounder Station IZ7004 Power Rack Station IZ7005 DAP Station IZ7006 Connector IZ7007 Stair-2×2	7489×3139×2446(mm) 294.8×123.6×96.3(in)	IZ7009 Step Attachment IZ7010 DIP Attachment IZ7012 Pivot Kettlebell, Punching Bag, Battle Rope, TRX, Medicine ball, Bar, Plate etc.



STRETCHING STATION

IZ7001

PRODUCT DIMENSION (L×W×H)	1655×683×2364 (mm) 65.2×26.9×93.1 (in)
PRODUCT WEIGHT	126.6 Kg / 279 Lbs
40'	57 Sets

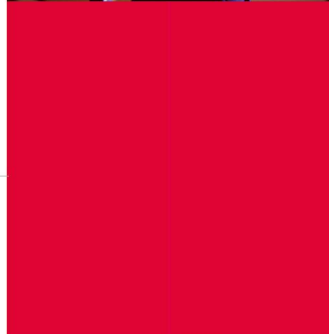

BOXING STATION

IZ7002

PRODUCT DIMENSION (L×W×H)	1655×1126×2377 (mm) 65.2×43.3×93.6 (in)
PRODUCT WEIGHT	135.9 Kg / 300 Lbs
40'	57 Sets

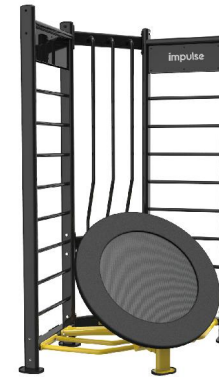

REBOUNDER STATION

IZ7003

PRODUCT DIMENSION (L×W×H)	1655×1072×2340 (mm) 65.2×42.2×92.1 (in)
PRODUCT WEIGHT	153.6 Kg / 339 Lbs
40'	61 Sets



POWER RACK STATION

IZ7004

PRODUCT DIMENSION (L×W×H)	1747×1409×2443 (mm) 68.8×55.5×96.2 (in)
PRODUCT WEIGHT	167 Kg / 368 Lbs
40'	120 Sets



DAP STATION

IZ7005

PRODUCT DIMENSION (L×W×H)	2386×957×2365 (mm) 93.9×37.7×93.1 (in)
PRODUCT WEIGHT	380.4 Kg / 839 Lbs
40'	56 Sets

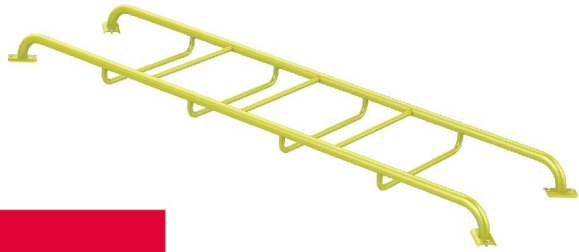
**STAIR-1****IZ7008**

PRODUCT DIMENSION (L×W×H)	3510×1010×205 (mm) 138.2×40×8.1 (in)
PRODUCT WEIGHT	43 Kg / 94.8 Lbs
40'	60 Sets

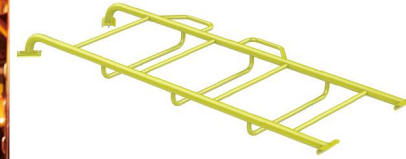
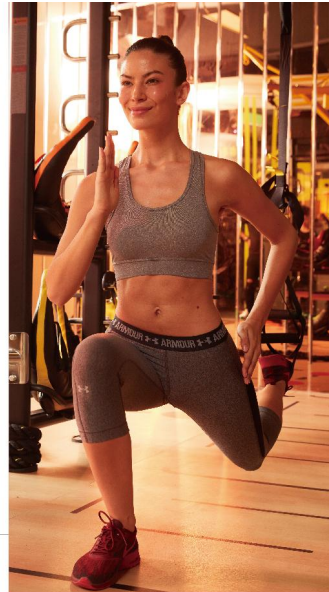
**STAIR-2****IZ7007**

PRODUCT DIMENSION (L×W×H)	2850×1117×204 (mm) 112.2×44×8 (in)
PRODUCT WEIGHT	38.3 Kg / 84.5 Lbs
40'	78 Sets

**PIVOT****IZ7012**

PRODUCT DIMENSION (L×W×H)	530.5×126×178 (mm) 20.9×5×7 (in)
PRODUCT WEIGHT	5.9 Kg / 13 Lbs
40'	5083 Sets

**STAIR-3(for O-Shape)****IZ7014**

PRODUCT DIMENSION (L×W×H)	2435×1207×205 (mm) 95.9×47.5×8 (in)
PRODUCT WEIGHT	35.6 Kg / 78.5 Lbs

**DIP ATTACHMENT****IZ7010**

PRODUCT DIMENSION (L×W×H)	940×624×289 (mm) 37×24.6×11.4 (in)
PRODUCT WEIGHT	12.6 Kg / 28 Lbs
40'	245 Sets

**CONNECTOR****IZ7006**

PRODUCT DIMENSION (L×W×H)	1528×178×205 (mm) 60.2×7×8.1 (in)
PRODUCT WEIGHT	13.9 Kg / 30.6 Lbs
40'	660 Sets

**STAIR-4(for H-Shape)****IZ7015**

PRODUCT DIMENSION (L×W×H)	2406×1704×205 (mm) 94.7×67.1×8 (in)
PRODUCT WEIGHT	35.6 Kg / 78.5 Lbs

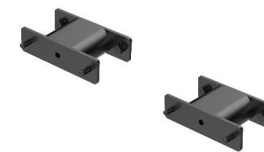
**S-JOINT****IZ7011**

PRODUCT DIMENSION (L×W×H)	178×100×50 (mm) 7×3.9×2 (in)
PRODUCT WEIGHT	2.6 Kg / 5.7 Lbs
40'	13066 Sets

**STEP ATTACHMENT****IZ7009**

PRODUCT DIMENSION (L×W×H)	749×650×289 (mm) 29.5×25.6×11.4 (in)
PRODUCT WEIGHT	16.3 Kg / 36 Lbs
40'	315 Sets

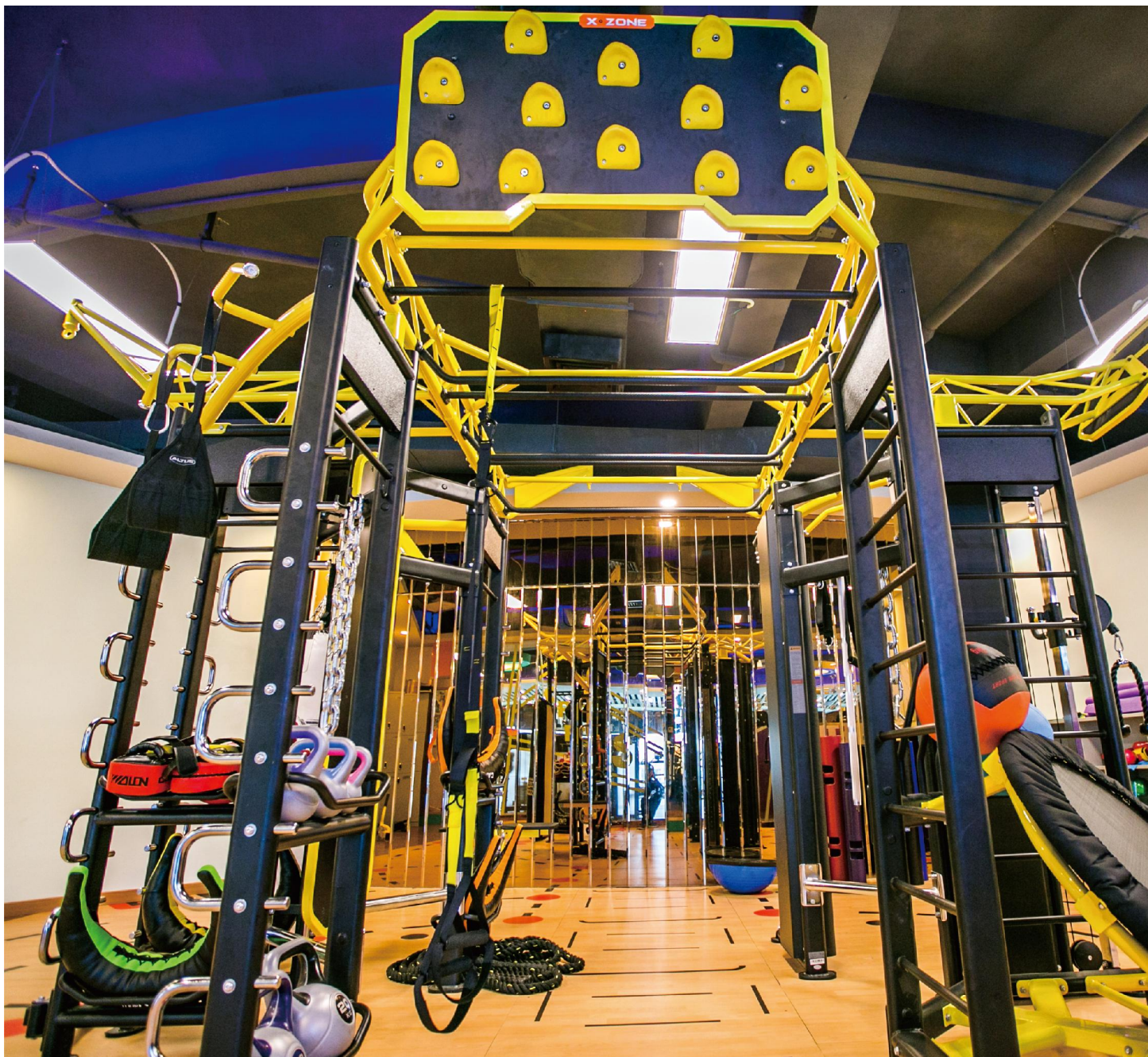

X-ZONE

Elite Group Functional Training Stations

X-zone is advanced and functional group training system which developed and updated from “H” shaped station of I-Zone.

- **Advancements:** integrated with Crossfit training method that can improve physical strength, explosive, speed, coordination and flexibility with X-zone.
- **Comprehensiveness:** X-zone can suit for beginner to advanced trainers and improve training effect in all directions
- **Efficiency:** maximize the value of indoor space through delicate structure design.

Place 5 advanced station on X-Zone training station

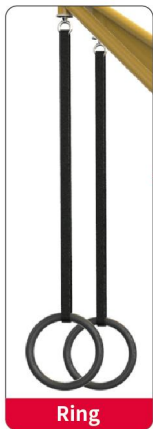

Ring



Climbing Rope

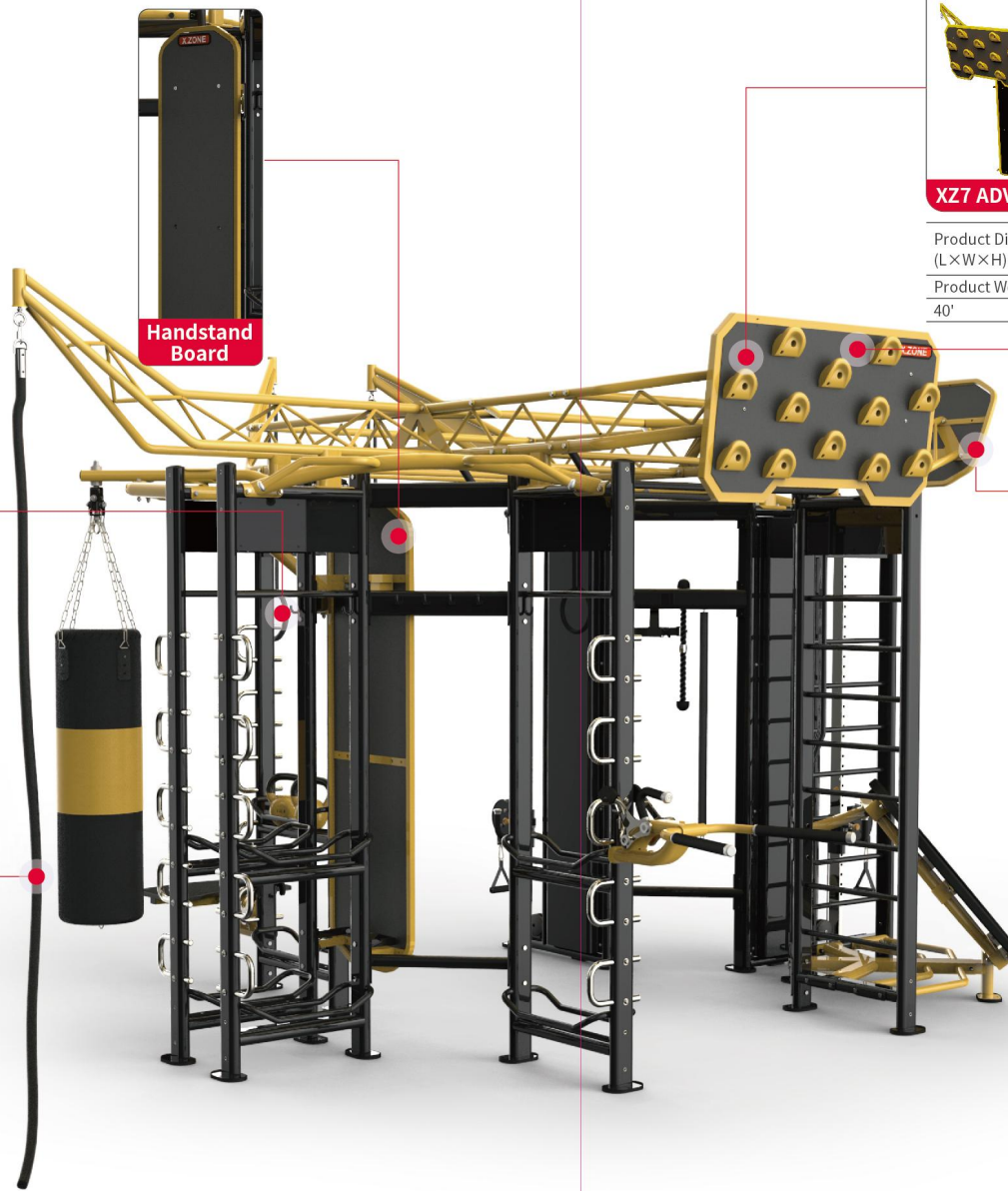

Handstand Board

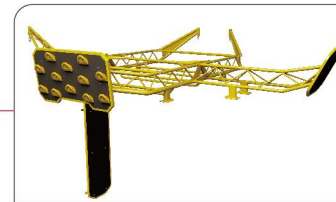

XZ7 ADVANCED TRAINING FRAME

Product Dimension (L×W×H)	5150×3570×2650(mm) 202.8×140.6×104.3(in)
Product Weight	229.5kg/504.9lbs
40'	24



Climbing



Wall Ball

Package-1	IZ7001 Stretching Station IZ7002 Boxing Station IZ7003 Rebounder Station IZ7005 DAP Station
Package-2	XZ7 Advanced Training Frame: Climbing Handstand Board Wall Ball
Assembly Size	5150x3570x3010(mm)
Optional Accessory Package	IZ7009 Step Attachment IZ7010 DIP Attachment IZ7012 Pivot XZ5001 ring XZ5002 climbing rope XZ5003 wall ball, Punching Bag, Kettlebell, Battle Rope TRX, Medicine Ball, Bar Plate, etc.

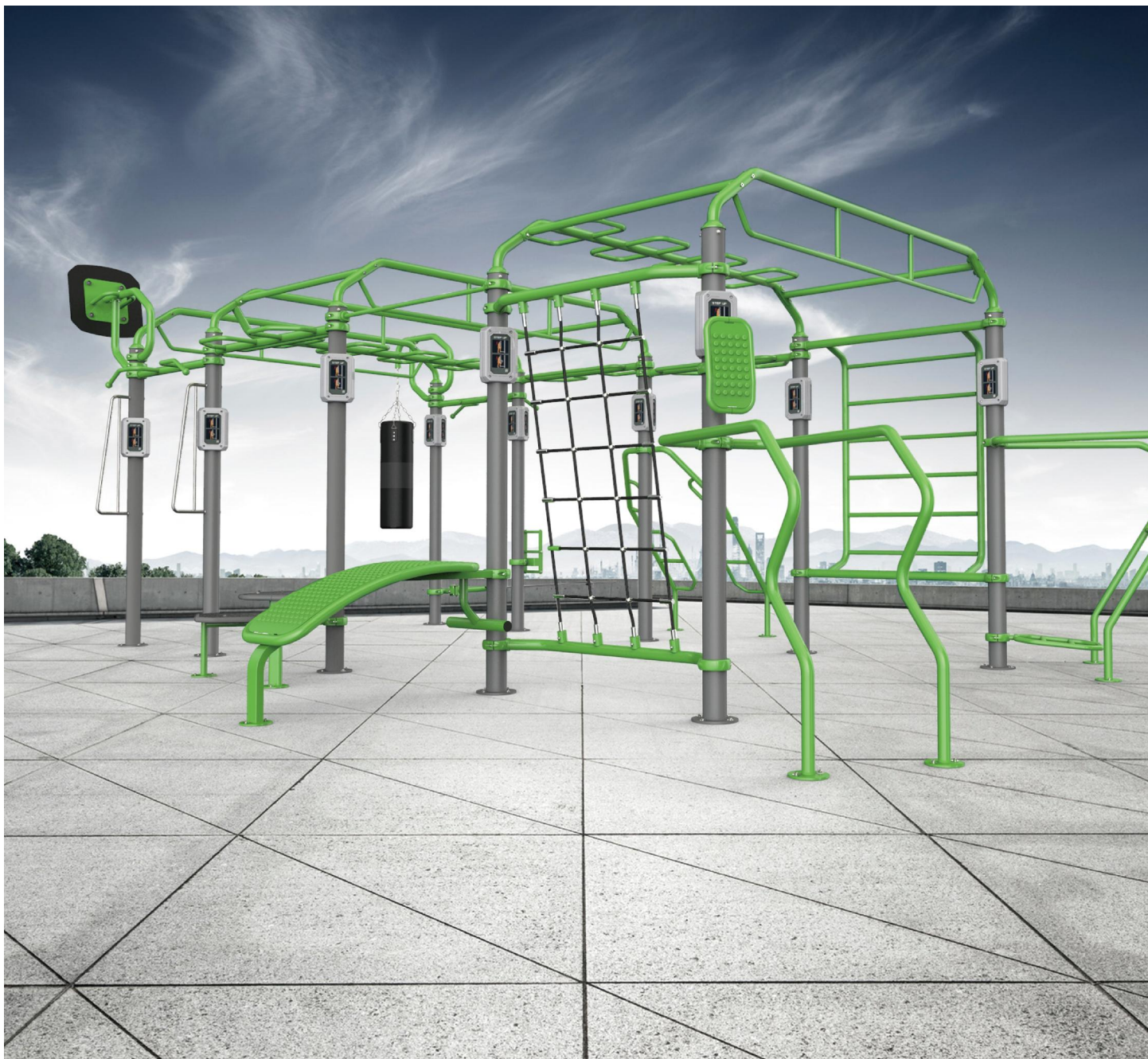

O-ZONE

Outdoor Training System

O-Zone is designed for outdoor use that can achieve functional and body weight training with free combination. O-Zone provides different training levels to meet the diversified use condition.

- Professional outdoor training:
Set up one systematic training system and novel training method with O-Zone
- Diversified modularized station:
Customized units which combined with 4 training station and 8 different modularized body weight training adds-on. Design for outdoor use, small group training and individual training.
Special coating for outdoor used
- High-quality preservative top coating for outdoor use to defend extreme environments.



Mini Station



Mini-plus Station



Expansion Station



All-round Station



Mini Training System

OZ7400

Product Dimension (L*W*H) mm	1660×3500×2481
Max Size with Optional Stations (mm)	8000×6500
Max Recommended Outdoor Space with Optional Station (mm)	12300×10800
SETS/40'HQ	28
Caution:	Combine X (0-4) station with Y (8-X) billboards(OZ5010)



Expansion Training System

OZ7800

Product Dimension (L*W*H) mm	4880×3500×2481
Max Size with Optional Stations (mm)	8000×9500
Max Recommended Outdoor Space with Optional Station (mm)	12300×13800
SETS/40'HQ	11
Caution:	Combine X (0-8) station with Y (14-X) billboards(OZ5010)

4 different training station that can fit to various outdoor space.



Mini-plus Training System

OZ7600

Product Dimension (L*W*H) mm	3400×3500×2481
Max Size with Optional Stations (mm)	8000×8000
Max Recommended Outdoor Space with Optional Station (mm)	12300×12300
SETS/40'HQ	12
Caution:	Combine X (0-6) station with Y (11-X) billboards(OZ5010)



All-round Training System

OZ7100

Product Dimension (L*W*H) mm	6070×3620×2481
Max Size with Optional Stations (mm)	8000×1100
Max Recommended Outdoor Space with Optional Station (mm)	12300×15000
SETS/40'HQ	10
Caution:	Combine X (0-9) station with Y (16-X) billboards(OZ5010)

Combining basic training station with one or several proper body training components to meet the demand of diversification and multi-functional training.



ROW
OZ5001
Product Dimension (mm) 1280×1080×1382
SETS/40'HQ 36



Step
OZ5002
Product Dimension (mm) 900×1200×421
SETS/40'HQ 240

Caution

1. Row, press, dip, wall ball and boxing can be placed on corner pillars
2. wall ball and boxing can not be placed on to pillar of ladder
3. Nothing can be placed on to corner pillar of weight rack if it is not in the corner
4. row, press can not be placed on to the corner pillar of Olympic rack.



Battle Rope Attachment
OZ5003
Product Dimension (mm) 223×285×400
SETS/40'HQ 2450

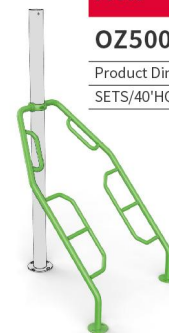

Press
OZ5004
Product Dimension (mm) 1100×1050×1470
SETS/40'HQ 161



Dip
OZ5005
Product Dimension (mm) 650×1400×1720
SETS/40'HQ 105



AB
OZ5006
Product Dimension (mm) 1590×475×630
SETS/40'HQ 108

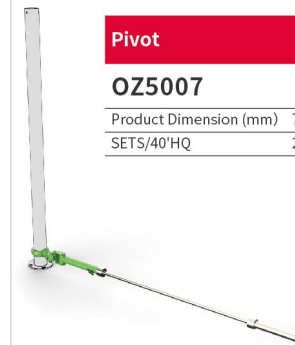

Pivot
OZ5007
Product Dimension (mm) 750×164×51
SETS/40'HQ 2880



Wall Ball
OZ5008
Product Dimension (mm) 600×835×2785
SETS/40'HQ 204

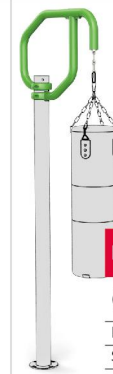

Boxing
OZ5009
Product Dimension (mm) 860×164×2540
SETS/40'HQ 507

TURKEY

CASES

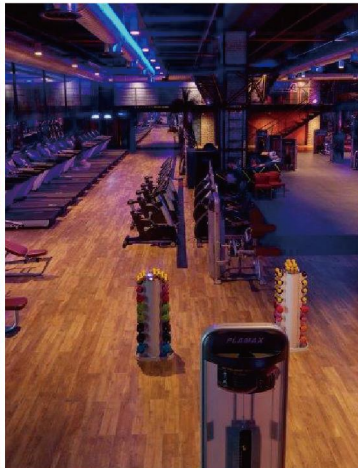
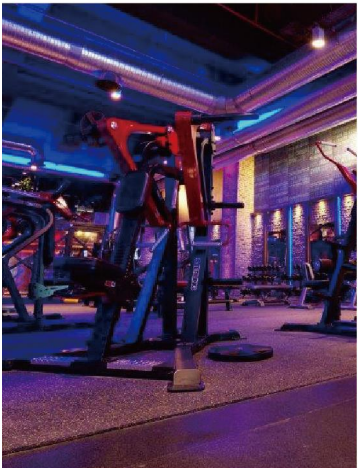
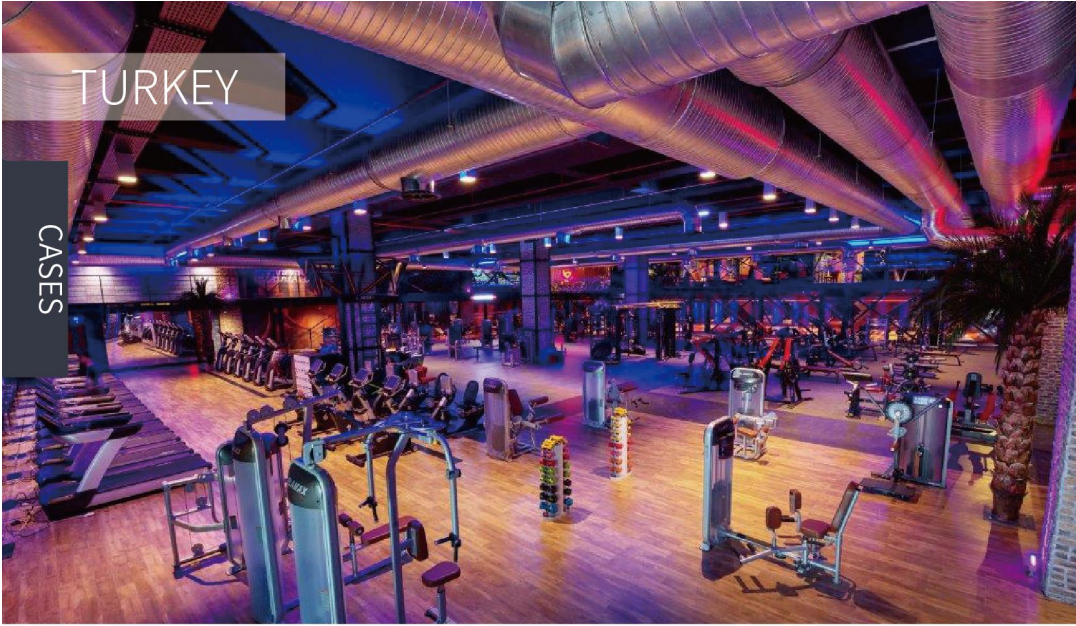

CASES



BOLIVIA



SOUTH AFRICA

CASES



CASES

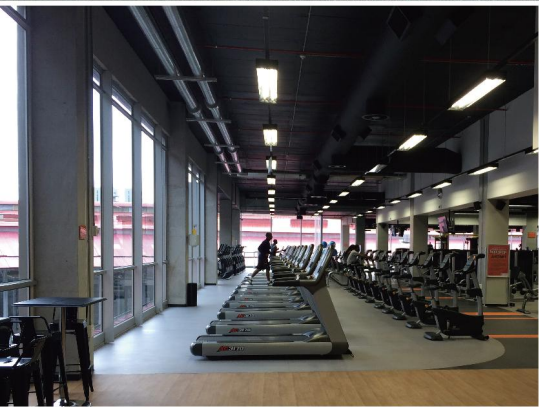

POLAND

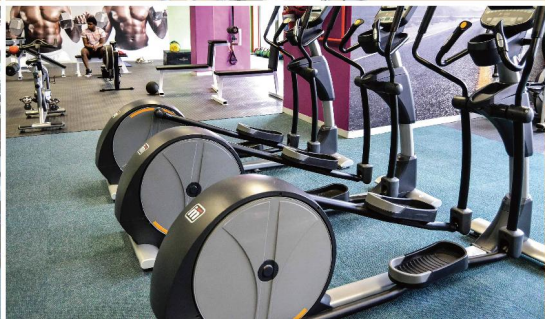



ITALY

CASES



CASES



NEW ZEALAND



SOUTH KOREA



VIETNAM

CASES



INDIA



CASES



VENEZUELA

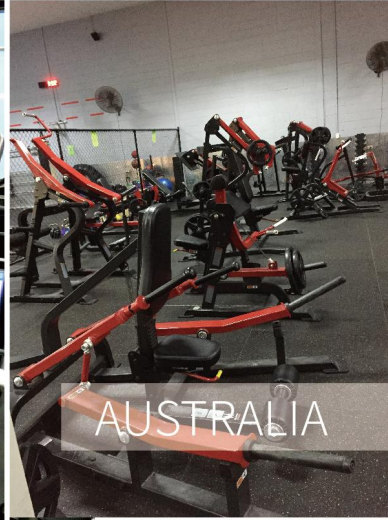

AUSTRALIA



CHINA

CASES



Impulse Cardiovascular Equipment Limited Warranty

Description	Warranty
Frame	7 Years
Treadmill AC Motor	3 Years
Treadmill DC Motor, Structural Moving Parts	2 Years
Display PCB, Motor Controller, Generator, EMS, ECB Brake	2 Years
Key Pad, Durable Wear Parts	1 Year

Impulse Strength Training Equipment Limited Warranty

Description	Warranty
Structural Steel Frame	Lifetime
Rotary Bearings, Weight Stacks, Pulleys, Guide Rods, Structural Moving Parts	2 Years
Cable, Linear Bearings, Springs	1 Year
Upholstery, Handgrips, All Other Items Not Listed	6 Months

* Conditions and Restrictions Applied.



in impulse

THE WAY TO WELLNESS

All text, picture and data in this catalogue are for reference only. If there is inconsistency between the information and the actual product, the actual product shall govern. Impulse reserves all rights to explain any error or difference in this catalogue.

Statement: Impulse Branding is upgrading and during that time, **in impulse** and **impulse** are still trademarks of Impulse products. Thank you for your support as always.